

PM Series – PW Type Worm Gear Units

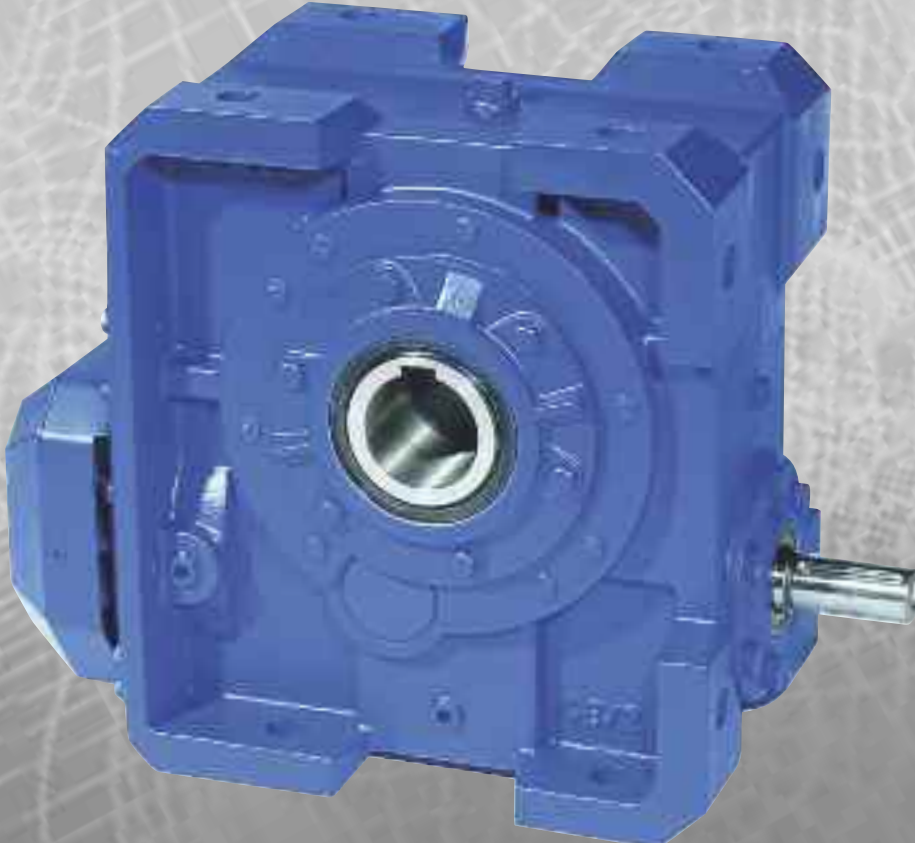

RENOLD
Superior Gear Technology

RENOLD PM Series - PW Type Product Features

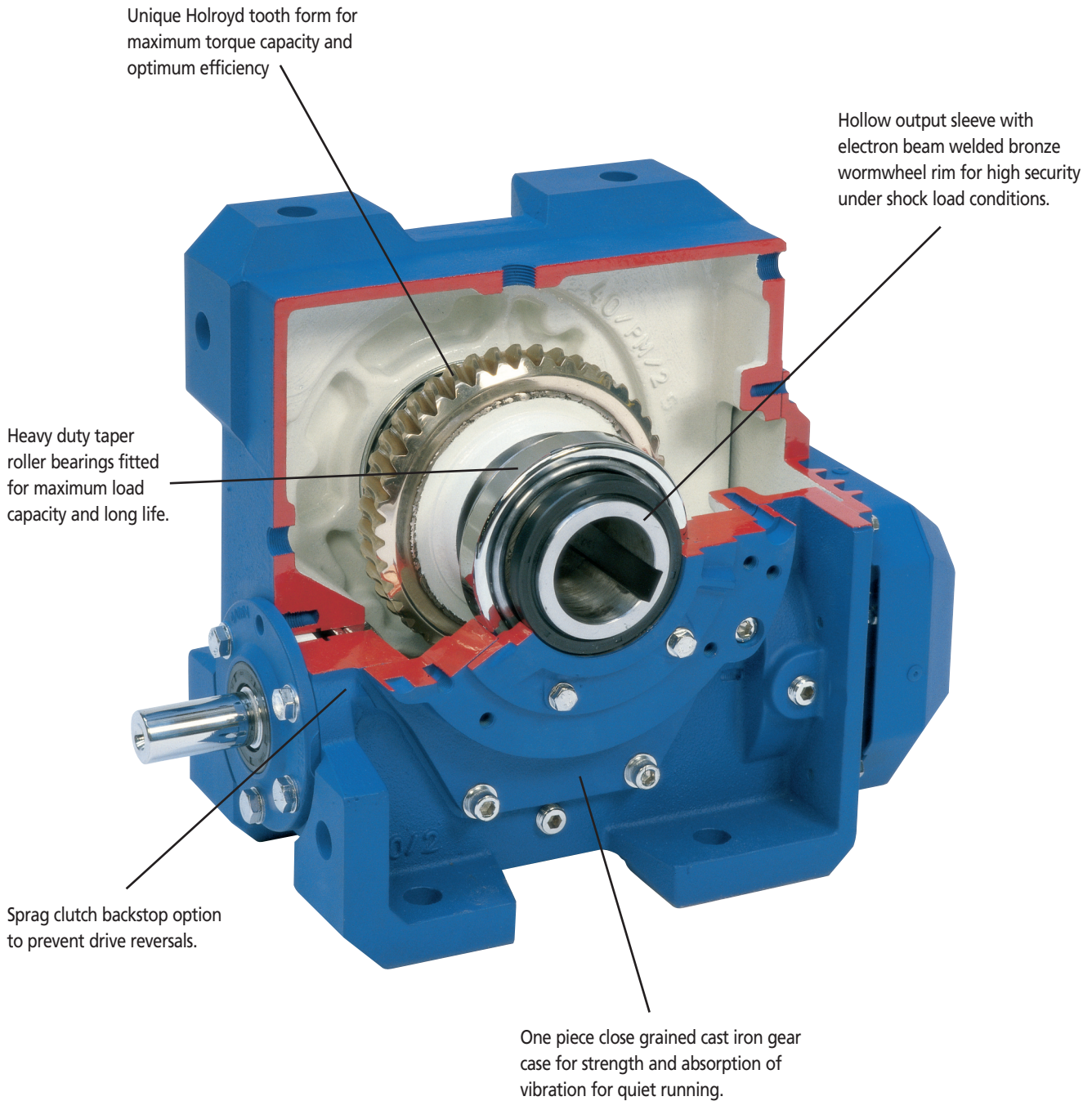

Applications:

- Conveyors
- Mining
- Timber
- Textiles
- Materials Handling
- Packaging Machinery
- Food Process Machinery
- Water Treatment
- Foundry equipment
- General Industrial Applications



Section of electron beam welded wormwheel rim and centre showing the fusion of the bronze wormwheel rim onto the cast iron centre. This high security fit allows transmission of power under shock load conditions.

Contents

	Page No
PM Series - PW Type Unit Product Features	2
ATEX Approval Details	4
General Specification	5
Product Design Variations	6 - 7
Unit Mounting and Handing Details	8 - 9
Electric Motor Specifications	10 - 12
Ordering Designation Code	13
Inertia Values	14
Selection of PM Series - PW Type Unit	15 - 16
Load Classification by Application	17
Overhung and Thrust Loads	18
Motorised Unit - Selection Data	19 - 31
Motorised Unit - Dimensions	32 - 35
Speed Reducer Unit - Overhung and Axial Load Capacities	36
Speed Reducer Unit - Exact Ratio	37
Speed Reducer Unit - Selection Data	38 - 51
Speed Reducer Unit - Dimensions	52 - 54
Plug-in Output Shaft Dimensions	55
Torque Restraint Bracket	56
Shrink Disc	57
Torque Arm Assembly	58
Installation, Maintenance and Storage	59
Lubrication	60
Oil Capacities	61
Weights	62 - 63

ATEX Approval Details

ATEX Approval

RENOLD Gears products for operating in potentially explosive atmospheres.

General

- **RENOLD** Gears units are classified as ATEX Group II Category 2 equipment, which embodies sufficient safeguards to be suitable for use in potentially explosive atmospheres for normal operation and for operation during an expected malfunction.
- It is essential that there is sufficient lubricant to prevent the gears and bearings running 'dry'. Gear units should be inspected daily for signs of oil leakage, overheating or noisy operation.
- Gear units should be cleaned at regular intervals depending on the operating conditions, to ensure that dust coatings never exceed 5mm. Plastic parts should be wiped clean with a damp cloth.
- Oil leaks should be dealt with as quickly as practical. Compound joint faces and shims should be cleaned and thread-locking sealant should be applied to bolts and plugs prior to re-assembly.

- The temperature of any external surfaces must not exceed the permitted maximum of 135°C (T4).
- Higher temperature class T3 is available dependant on unit mounting, ratio and gear type. For further details consult **RENOLD**.
- As a general rule, gear units should be mounted with their feet horizontal. For other mountings, particularly with shaft mounted units, consult **RENOLD** Gears.

WARNING: IF MOUNTING WITH VERTICAL INPUT OR OUTPUT SHAFTS, THE ATEX CERTIFICATION DOES NOT APPLY.

Unit Selection

- The gear unit selection procedures must include an additional reliability factor of 1.25 for mechanical ratings and 1.25 for thermal ratings.

ATEX Nameplate

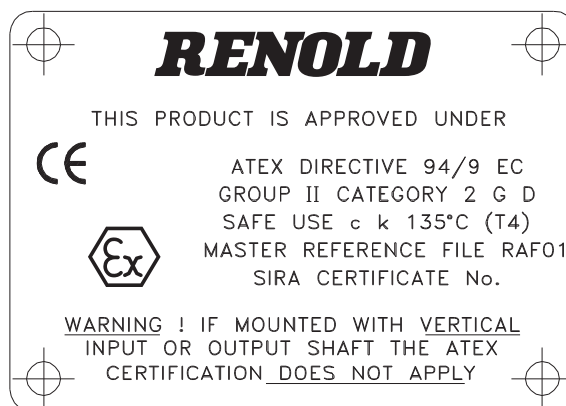

RENOLD PM Series - PW Type Product Specification

Gear Case

The gear cases are of close grained cast iron with all joints and bearing bores accurately machined to ensure oil tightness and precise gear location.

Wormshaft and Wormwheel

The worm is integral with its shaft and manufactured from alloy steel, casehardened on the threads and ground and polished on the thread profiles.

The wormwheel rim is made from bronze complying with BS 1400 PB2-C (centrifugally cast) and secured to the cast iron centre by the electron beam welding process.

The Holroyd gear form used in the **RENOLD** PM Series gear units corresponds to British Standard recommendations but, in addition, has an exclusive feature which consists principally of an important modification to the worm threads and wheel teeth which confer additional valuable properties to gear performance. This ensures that our gears will run correctly and transmit true uniform angular velocity when running under all load conditions. The modification also gives a tapered oil entry gap between the teeth, which drags the lubricant between the surfaces and results in more efficient lubrication. Standard worm gears have right-hand threads but left-hand threads can be made to order.

Shafts

Standard shaft extensions are to metric dimensions, but imperial shaft extensions for units complying with BS3027: 1968 or to suit the requirements of the North American market are also available. The output Shaft is manufactured in carbon steel, but if required by applicational conditions, can be made from high tensile steel, in single or double extension.

Preferred Ratios

Certain gear ratios have been nominated as preferred ratios and are shown on pages 38 - 51. This has been done with a view to providing a competitive lead time.

Bearings

Standard metric taper/roller bearings are fitted throughout the **RENOLD** PM Series range of units in both single and double extension shaft options.

Oil Seals

Semi-dual lip oil seals are fitted to all hollow output shaft units.

Dry Well Feature

The **RENOLD** PM Series unit can be factory fitted with a 'dry-well' adaption at the output shaft to create a non oil leak unit. The output shaft bearing within the dry well is grease lubricated.

The non leak feature is particularly important on mixer drive applications in food and chemical plants where the unit shaft is vertically down.

Lubrication

Gear and bearings are positively lubricated by oil from the sump in the underdriven and overdriven versions at normal motor speeds. With the vertical type, grease lubrication is necessary to the wheeline bearings.

For lower speeds it may be necessary to consider grease lubrication of certain bearings and in this instance it is advisable to consult with Renolds Engineers. Full lubrication details can be found under the "Installation & Maintenance" section.

Cooling

Maximum heat dissipation by air cooling is carried out by a radial fan directing air over ribbed gear case. Where applicational circumstances permit, standard units can be supplied without a fan.

Backstop

Sprag clutch backstops can be fitted to all speed reducer units to prevent unit run back when required. Motorised units can be fitted with backstops, please consult Renold.

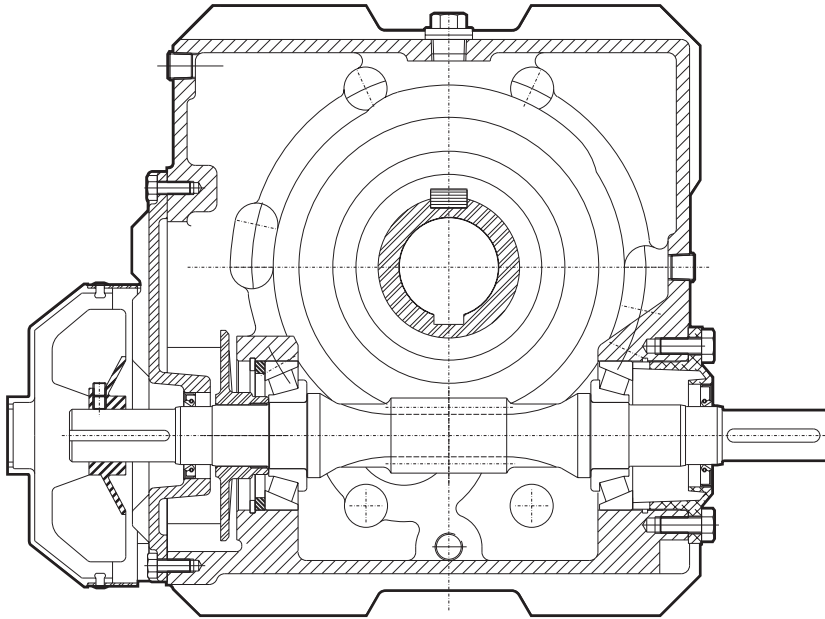

Hollow output shaft unit showing standard metric extension input shaft and American extension at the fan end.

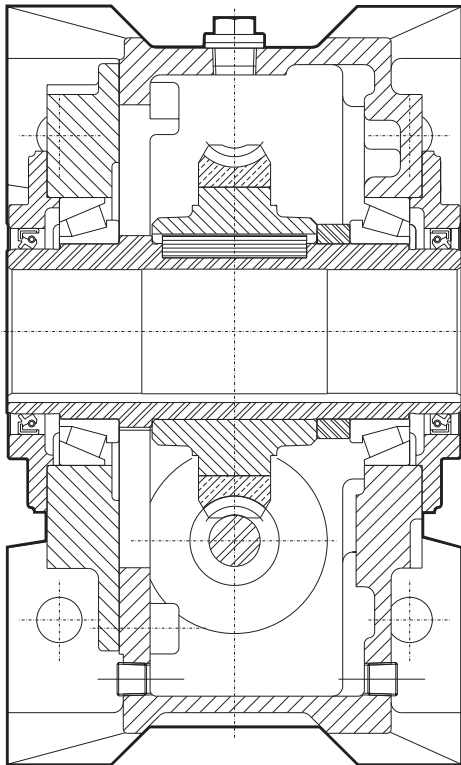

Standard hollow output shaft with semi dual lip oil seal for added oil retention

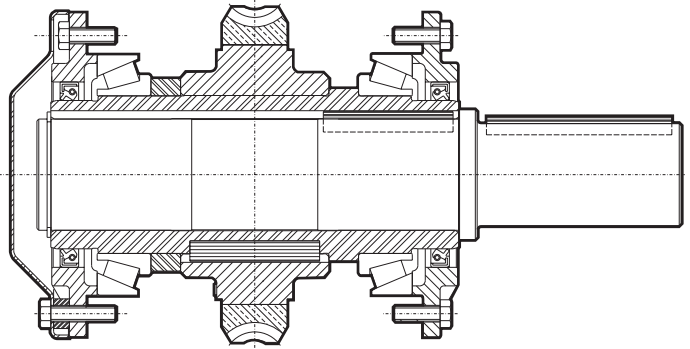

Standard plug-in output shaft. Single and double extension shafts are available with metric and American dimensions.

RENOLD PM Series PW Type - Product Design Variations

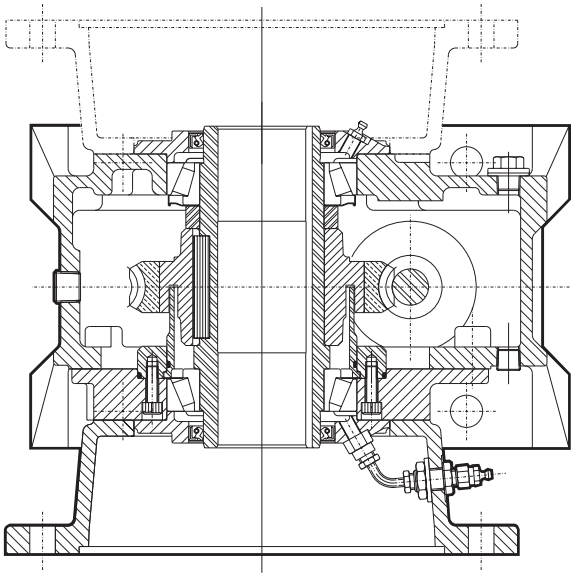

Unit fitted with output location flange and dry well adaption at the output of the PM Series unit. The non leak feature is particularly important on mixer applications in the food and chemical Industry.

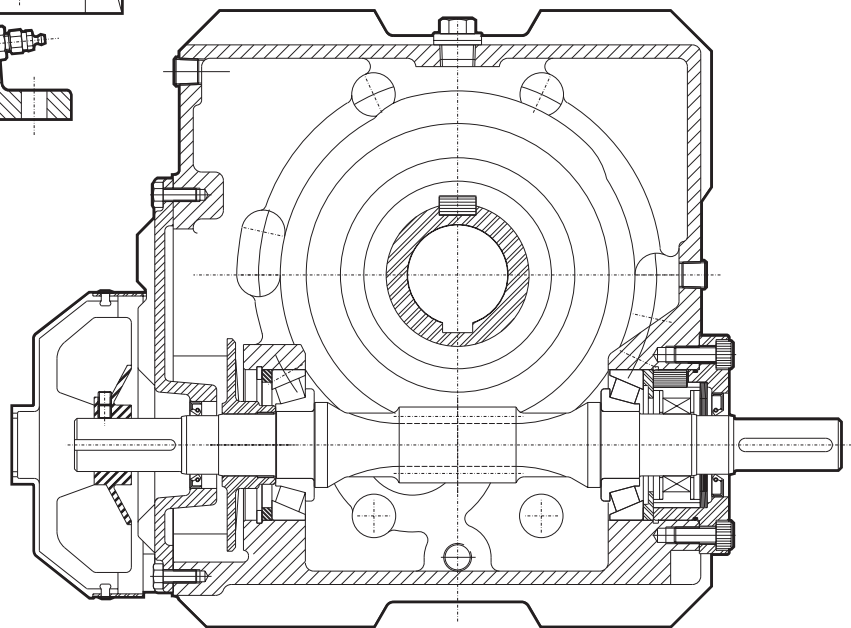

Sprag Clutch, anti run-back assembly fitted to the input shaft, to prevent unit run back. The Sprag Clutch can be supplied as a kit for retro fitting at any time.

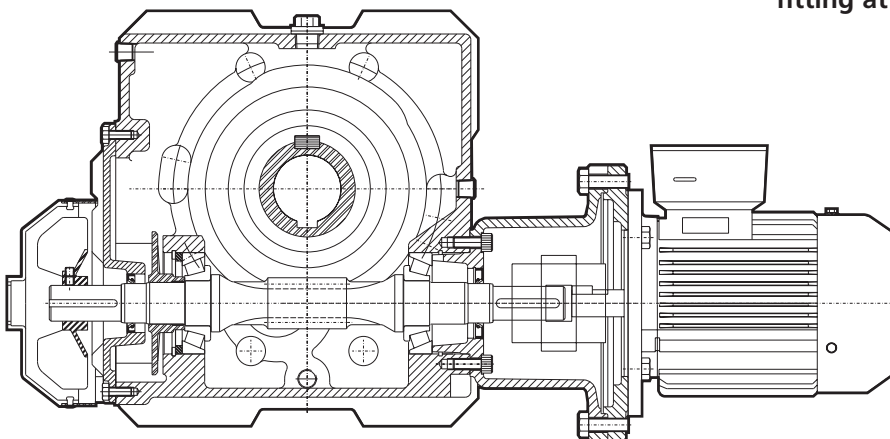

Motorised unit made to suit standard IEC and NEMA motors.

Underdriven

No Sprag backstop fitted.
Sprag backstop fitted.

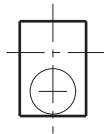

UA
UB

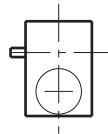

UC
UD

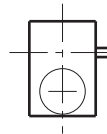

UE
UF

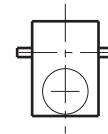

UG
UH

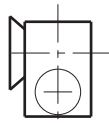

UJ
UK

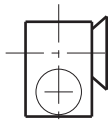

UL
UM

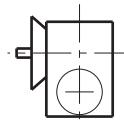

UN
UP



UQ
UR

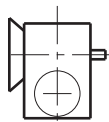

US
UT

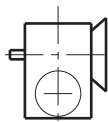

UU
UV

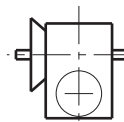

UW
UX

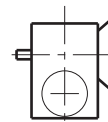

UY
UZ

No Sprag backstop fitted.
Sprag backstop fitted.

Overdriven

No Sprag backstop fitted.
Sprag backstop fitted.

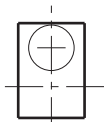

OA
OB

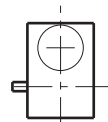

OC
OD

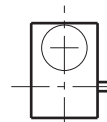

OE
OF

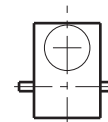

OG
OH

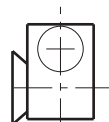

OJ
OK

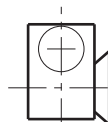

OL
OM

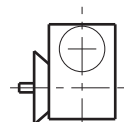

ON
OP

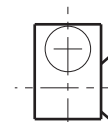

OQ
OR

No Sprag backstop fitted.
Sprag backstop fitted.

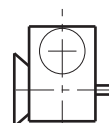

OS
OT

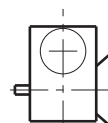

OU
OV

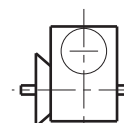

OW
OX

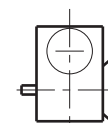

OY
OZ

No Sprag backstop fitted.
Sprag backstop fitted.

RENOLD PM Series - Single Reduction - Mounting & Handing

Vertical

No Sprag backstop fitted.
Sprag backstop fitted.

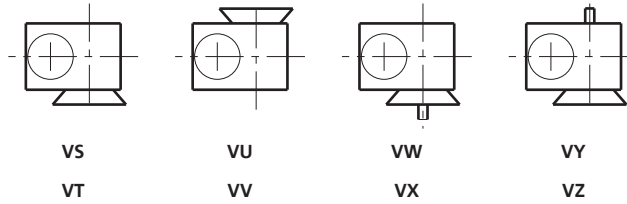

No Sprag backstop fitted.
Sprag backstop fitted.

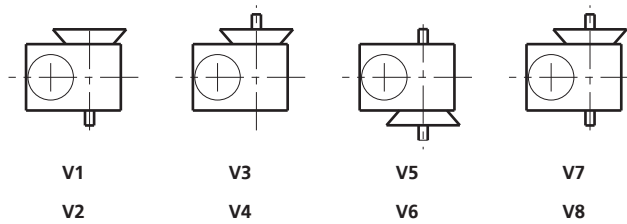

Wall Mounting

No Sprag backstop fitted.
Sprag backstop fitted.

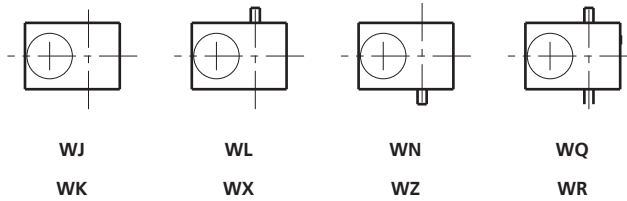

PW Type with dry well sump (Factory Built)

NOTE: Sprag Backstops are not available on PW Type Motorised Units.

Rotation

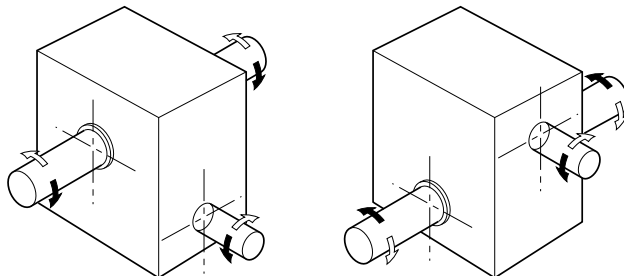

The diagrams above illustrate the relative directions of rotation of the input and output shafts.

All PM series gear units are reversible.

Electric Motor Specification

4POLE/1500 RPM

DMA1 = aluminium series 1 DM1 = cast iron series 1 IEC-DIN			Rated Output Power PN kW	Full Load Current			Full-Load Speed nN min-1	Full-Load Power Factor cos	Full-Load Efficiency %	Locked Rotor Current La/LN	Locked Rotor Torque Ma/MN	Breakdown Torque Mk/MN	Moment of Inertia J kgm2	Nett Weight IM B3 m kg
				380 V IU A	400 V IN A	420 V IO A								
DMA1	80	K4	0.55	1.58	1.55	1.56	1365	0.79	64.7	4.0	1.8	2.1	0.001146	8.9
DMA1	80	G4	0.75	2.00	1.99	2.00	1345	0.80	67.9	4.0	2.0	2.3	0.001263	9.6
DMA1	90	S4	1.10	2.75	2.76	2.73	1380	0.78	72.8	4.6	2.1	2.4	0.002761	12.5
DMA1	90	L4	1.50	3.72	3.78	3.93	1370	0.77	73.9	4.6	2.1	2.4	0.003283	15.0
DMA1	100	L4	2.20	5.13	5.12	4.80	1430	0.76	80.5	5.7	2.2	2.7	0.003119	19.2
DMA1	100	LX4	3.00	6.78	6.66	6.51	1400	0.82	79.5	5.2	2.0	2.6	0.004704	23.0
DMA1	112	M4	4.00	8.93	8.48	8.08	1430	0.82	83.2	5.8	2.1	2.6	0.006418	29.0
DMA1	132	S4	5.50	11.80	11.39	10.84	1435	0.85	82.3	6.5	2.0	2.5	0.013249	43.5
DMA1	132	M4	7.50	15.77	15.50	14.77	1435	0.82	84.8	6.5	2.2	2.5	0.016912	61.0
DM1	160	M4	11.00	22.1	21.2	21.3	1450	0.85	88.1	7.6	2.5	3.0	0.0724	113
DM1	160	L4	15.00	27.6	28.1	28.2	1460	0.86	89.5	7.9	2.7	3.1	0.0929	133
DM1	180	M4	18.50	35.3	33.4	33.4	1470	0.88	90.9	7.5	2.5	3.0	0.1350	167
DM1	180	L4	22.00	42.0	39.8	39.5	1465	0.88	90.9	7.5	2.2	3.1	0.1360	181
DM1	200	L4	30.00	55.6	53.3	52.0	1480	0.88	92.0	7.2	2.5	3.2	0.2450	232
DM1	225	S4	37.00	68.2	65.5	64.0	1485	0.88	92.3	7.3	2.0	2.8	0.3900	287
DM1	225	M4	45.00	81.3	79.1	76.0	1480	0.89	92.4	7.5	2.2	3.0	0.4500	322
DM1	250	M4	55.00	101	96.0	95.0	1480	0.89	93.0	7.0	2.3	3.1	0.6400	381
DM1	280	S4	75.00	137	131	126	1480	0.88	93.5	6.1	2.0	2.9	1.0450	510
DM1	280	M4	90.00	168	152	155	1485	0.88	94.2	7.8	2.7	3.3	1.3960	600

6POLE/1000 RPM

DMA1 = aluminium series 1 DM1 = cast iron series 1 IEC-DIN			Rated Output Power PN kW	Full Load Current			Full-Load Speed nN min-1	Full-Load Power Factor cos	Full-Load Efficiency %	Locked Rotor Current La/LN	Locked Rotor Torque Ma/MN	Breakdown Torque Mk/MN	Moment of Inertia J kgm2	Nett Weight IM B3 m kg
				380 V IU A	400 V IN A	420 V IO A								
DMA1	80	K6	0.37	1.19	1.26	1.26	915	0.67	63.0	3.5	2.0	2.4	0.001268	8.5
DMA1	80	G6	0.55	1.81	1.85	X.XX	900	0.71	60.5	3.2	2.0	2.3	0.001392	9.2
DMA1	90	S6	0.75	2.35	2.31	2.30	910	0.71	65.6	3.5	2.0	2.3	0.00316	12.0
DMA1	90	L6	1.10	3.38	3.44	3.40	910	0.67	69.1	3.7	2.1	2.3	0.003794	14.0
DMA1	100	L6	1.50	3.92	3.88	3.87	935	0.76	73.3	4.1	1.9	2.2	0.004605	19.5
DMA1	112	M6	2.20	5.79	5.48	5.24	945	0.75	77.4	5.0	2.0	2.4	0.006949	28.0
DMA1	132	S6	3.00	7.39	7.07	6.97	960	0.78	78.3	5.4	1.8	2.2	0.012912	50.0
DMA1	132	M6	4.00	9.44	9.35	9.60	955	0.77	80.6	5.4	1.9	2.1	0.016082	58.0
DMA1	132	MX6	5.50	13.00	12.60	12.80	955	0.77	84.3	5.4	2.0	2.4	0.019174	65.0
DM1	160	M6	7.50	16.1	15.9	16.0	965	0.79	85.3	6.5	1.8	3.0	0.0800	108
DM1	160	L6	11.00	22.7	22.4	22.6	970	0.8	87.8	7.1	1.8	3.1	0.1080	131
DM1	180	L6	15.00	29.5	29.3	29.1	980	0.83	89.2	7.2	2.5	2.9	0.1670	171
DM1	200	L6	18.50	36.5	35.5	35.1	980	0.84	89.9	6.7	2.0	3.0	0.3020	216
DM1	200	LX6	22.00	42.3	40.6	39.8	975	0.87	89.8	6.7	2.0	2.8	0.3420	225
DM1	225	M6	30.00	57.6	55.4	54.2	985	0.85	91.7	6.2	2.3	2.8	0.5250	292
DM1	250	M6	37.00	69.5	67.3	65.7	985	0.87	91.5	6.8	2.1	3.1	0.8070	408
DM1	280	S6	45.00	79.1	80.2	77.3	985	0.88	92.4	6.5	2.0	2.9	1.3340	465
DM1	280	M6	55.00	97.6	99.0	95.4	985	0.87	92.7	6.7	2.1	3.0	1.5980	540

Electric Motor Dimensions

DM1 : 4 POLE/1500 RPM

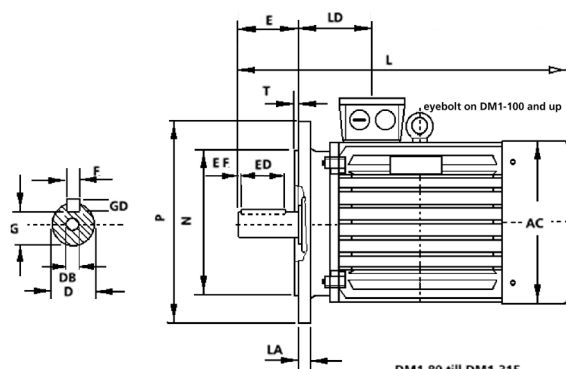

DM1-80 till DM1-315

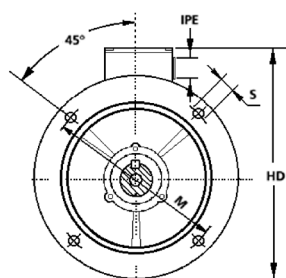

DM1-80 till DM1-200

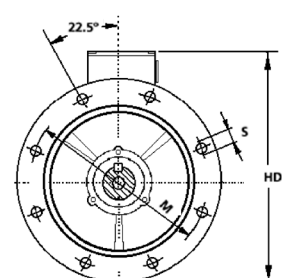

DM1-225 till DM1-280

Type	Frame	Poles	AC	D	E	ED	EF	F	G	GD	HD	L	LA	LD
DMA1	80	4/6	146	19	40	25	7.5	6	15.5	6	224	268	12	83
DMA1	90S	4/6	158	24	50	32	7.5	8	20	7	230	312	12	88
DMA1	90L	4/6	158	24	50	32	7.5	8	20	7	230	332	12	88
DMA1	100	4/6	190	28	60	45	7.5	8	24	7	271	367	15	83
DMA1	112	4/6	216	28	60	45	7.5	8	24	7	290	384	15	100
DMA1	132S	4/6	246	38	80	56	7.5	10	33	8	330	445	15	105
DMA1	132M	4/6	246	38	80	56	7.5	10	33	8	330	483	15	105
DM1	160M/MX	4/6	311	42	110	100	5.0	12	37	8	505	615	14	150
DM1	160L	4/6	311	42	110	100	5.0	12	37	8	505	670	14	150
DM1	180M	4/6	352	48	110	100	5.0	14	42.5	9	530	700	16	160
DM1	180L	4/6	352	48	110	100	5.0	14	42.5	9	530	740	16	160
DM1	200L/LX	4/6	394	55	110	100	5.0	16	49	10	580	770	17	190
DM1	225S	4	442	60	140	125	7.5	18	53	11	640	815	20	190
DM1	225M	4/6	442	60	140	125	7.5	18	53	11	640	845	20	190
DM1	250M	4/6	481	65	140	125	7.5	18	58	11	695	910	20	203
DM1	280S	4/6	543	75	140	125	7.5	20	67.5	12	770	995	23	220
DM1	280M	4/6	543	75	140	125	7.5	20	67.5	12	770	1045	23	220

Type	Frame	Poles	M	N	P	S	T	Flange	IPE	X	Y
DMA1	80	4/6	165	130j6	200	4x12	3.5	FF165	2xPg16	80	65
DMA1	90S	4/6	165	130j6	200	4x12	3.5	FF165	2xPg16	80	65
DMA1	90L	4/6	165	130j6	200	4x12	3.5	FF165	2xPg16	80	65
DMA1	100	4/6	215	180j6	250	4x15	4	FF215	2xPg16	80	65
DMA1	112	4/6	215	180j6	250	4x15	4	FF215	2xPg21	100	100
DMA1	132S	4/6	265	230j6	300	4x15	4	FF265	2xPg21	100	100
DMA1	132M	4/6	265	230j6	300	4x15	4	FF265	2xPg21	100	100
DM1	160M/MX	4/6	300	250j6	350	4x19	5	FF300	2xPg29	150	160
DM1	160L	4/6	300	250j6	350	4x19	5	FF300	2xPg29	150	160
DM1	180M	4/6	300	250j6	350	4x19	5	FF300	2xPg29	150	160
DM1	180L	4/6	300	250j6	350	4x19	5	FF300	2xPg29	150	160
DM1	200L/LX	4/6	350	300h6	400	4x19	5	FF350	2xPg36	188	208
DM1	225S	4	400	350h6	450	8x19	5	FF400	2xPg36	188	208
DM1	225M	4/6	400	350h6	450	8x19	5	FF400	2xPg36	188	208
DM1	250M	4/6	500	450h6	550	8x19	5	FF500	2xPg42	216	246
DM1	280S	4/6	500	450h6	550	8x19	5	FF550	2xPg42	216	246
DM1	280M	4/6	500	450h6	550	8x19	5	FF500	2xPg42	216	246

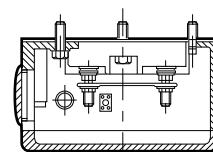
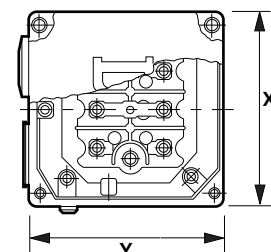

Electric Motor - Terminal Box Position

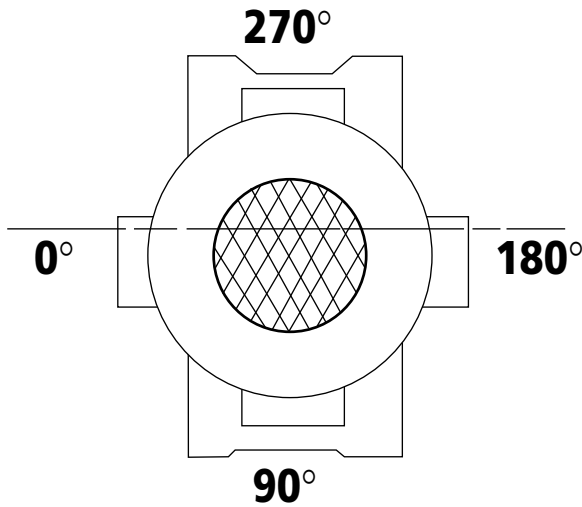

Terminal Box Position	
A	0°
B	90°
C	180°
D	270°

Unless otherwise specified-position 'A' will be issued.

Terminal Box

On motor sizes 71 to 225 the terminal box is an integral part of the frame.

Motor sizes 250 and above have a conventional terminal box that can rotate 180°. As standard in this range the terminal box entries are on the right side of the motor viewed from shaft end.

By rotating the terminal box, these entries can be transferred to the left side.

On the table below are the standard terminal arrangements and terminal box entries.

Motor Frame Size	Quantities and sizes		
	Terminals	Terminal box entries	
71	6 X M4	2 X Ø22,5	(1)
100	6 X M4	2 X Ø28,5	(1)
112	6 X M4	4 X Ø28,5	(2)
132	6 X M6	4 X Ø28,5	(2)
160	6 X M6	4 X Ø37	(2)
180	6 X M8	4 X Ø37	(2)
200 and 255	6 X M8	4 X Ø47	(2)
250 and 280	6 X M10	2 X Pg 42	(3)
315	6 X M10	2 X Pg 48	(3)
315 to 400	6 X M12	2 X Pg 48	(3)

- (1) One entry on each side
- (2) Two entries on each side
- (3) Two entries on the right side that can be transferred to the left side.

Alternative Types of TEFV Motors

Single phase	Capacitor start / induction run Permanent capacitor Capacitor start / capacitor run
Three phase	Squirrel cage standard motors Two speed Increased safety - Eex e Flameproof Exd. non sparking Exn. Brake motors Marine requirements Smoke extract duty High Efficiency motors Dust Ignition Proof - BS6467 Zone Z Force ventilation + Encoders + Tacho's Variable speed drives Motor-inverter combination Wash down Tropicalised DC Hydraulic Air

Ordering Procedure - Unit Designation Code

To ensure that the correct PM Series PW Type unit is supplied and that your order is processed without delay, please quote the full designation code as detailed below:

Motorised Unit

	PW4	25	D4P	040	UA	M	A	TS	
Unit type and size	Special features
Ratio	Motor terminal box (see page 12)
D flange 4 pole motor	Metric 'M' or American 'A' shafts
4kW motor	Unit hand of assembly (see page 8-9)

Motorised Ready Unit - To suit free issue motor

	PW5	05	D132RDY		UA	M	WP	
Unit type and size	Special features
Ratio	Metric 'M' or American 'A' shafts
D132 motor ready	Unit hand of assembly (see page 8-9)

Reduction Gear or Speed Reducer Unit

	PW5	Red XXX	70		UA	M	SS	
Unit type and size	Special features
Reduction gear	Metric 'M' or American 'A' shafts
Ratio	Unit hand of assembly (see page 8-9)

Special Features include:-

- BM - Braked motor
- SS - Slow speed running
- WP - Weather proof
- TR - Torque restraint bracket
- SD - Shrink disc
- TA - Torque arm bracket

RENOLD PM Series - PW Type Inertia Values WR^2 (kgm²)

Input shaft

Nominal Ratio	PW35	PW40	PW50	PW60	PW70	PW80
5/1	0.00128	0.00180	0.00354	0.01062	0.01235	0.01519
7.5/1	0.00128	0.00177	0.00351	0.01060	0.01235	0.01516
10/1	0.00128	0.00177	0.00351	0.01053	0.01225	0.01488
12.5/1	0.00132	0.00178	0.00350	0.01041	0.01226	0.01499
15/1	0.00128	0.00178	0.00347	0.01055	0.01226	0.01497
20/1	0.00143	0.00177	0.00352	0.01067	0.01243	0.01538
25/1	0.00133	0.00183	0.00351	0.01061	0.01228	0.01499
30/1	0.00128	0.00177	0.00350	0.01071	0.01208	0.01440
35/1	0.00125	0.00176	0.00349	0.01061	0.01233	0.01492
40/1	0.00123	0.00177	0.00349	0.01060	0.01226	0.01487
45/1	0.00123	0.00176	0.00345	0.01058	0.01243	0.01500
50/1	0.00122	0.00170	0.00348	0.01060	0.01223	0.01489
60/1	0.00121	0.00169	0.00336	0.01043	0.01206	0.01459
70/1	0.00121	0.00172	0.00343	0.01052	0.01222	0.01495

Input motor coupling

PW35	PW40	PW50	PW60	PW70	PW80
0.00108	0.00108	0.00344	0.00344	0.00850	0.02112

Hollow output shaft

Nominal Ratio	PW35	PW40	PW50	PW60	PW70	PW80
5/1	0.02000	0.05788	0.09476	0.21171	0.45604	0.67912
7.5/1	0.02000	0.05919	0.09360	0.21839	0.49789	0.68633
10/1	0.02000	0.05917	0.09367	0.21988	0.49482	0.70673
12.5/1	0.01915	0.05931	0.09434	0.22437	0.49579	0.69603
15/1	0.02000	0.05867	0.09605	0.21897	0.49541	0.70001
20/1	0.01797	0.06127	0.09584	0.21954	0.44430	0.67189
25/1	0.01915	0.05669	0.09774	0.21729	0.49655	0.69638
30/1	0.02000	0.05941	0.09562	0.20231	0.48478	0.75270
35/1	0.02071	0.05999	0.09635	0.21582	0.49734	0.70397
40/1	0.02164	0.05967	0.09705	0.21614	0.49529	0.70724
45/1	0.02188	0.06104	0.09915	0.21766	0.45838	0.69759
50/1	0.02222	0.06135	0.09849	0.21798	0.49491	0.70328
60/1	0.02270	0.06178	0.10136	0.22596	0.48787	0.77638
70/1	0.02331	0.06052	0.09794	0.21336	0.46622	0.69223

Plug-in output shafts

Type	PW35	PW40	PW50	PW60	PW70	PW80
Single Ext	0.00135	0.00305	0.00689	0.01972	0.03465	0.03846
Single Ext - Flanged	0.00178	0.00421	0.00868	0.02438	0.04309	0.04619
Double Ext	0.00169	0.00385	0.00884	0.02315	0.04157	0.04918
Double Ext - Flanged	0.00213	0.00500	0.01062	0.00278	0.05000	0.05763

See page 16 for example of total unit inertia.

RENOLD PM Series -Selection Information

To select a motorised or non-motorised gear unit for an application, the following information must be available.

Power/Torque

- a) Input or output (kW) or torque (Nm).
- b) Type and power output of prime mover (kW). Required mounting position.
- c) For input speeds below 250 rev/min consult our Technical Sales Department giving details of required output torque (Nm) and diameter of driven shaft (mm).

Speed

Gear unit input and output rev/min.

Duty

- a) The characteristics of the drive eg. degree of impulsiveness of the driven load.
 - b) Duration of service in hours/day.
 - c) Starting load (kW) and number of starts per day.
 - d) For intermittent duty, reversing or shock loading, state normal power (kW) and frequency.
 - e) Disposition and details of external loads imposed on input/output shafts. Diameter of driven shaft in the case shaft mounting arrangement.
 - f) Working conditions, i.e. clean, dusty, moist, abnormal temperatures etc.
- If the operating conditions are in any way unusual it is advisable to consult our Technical Sales Department.

Enquiry/Ordering Procedure

At the order or enquiry stage, please quote the catalogue reference, shaft assembly number and nominal ratio or exact ratio if this is important (see tables). Non standard mounting positions should be indicated with a sketch. Where a double extension wormwheel shaft is required, please state any special requirements regarding alignment of keyways.

Mechanical Rating

The mechanical powers listed are those which the PM Series units will transmit for 10 hours each day and correspond to a service factor of 1.0. Where non-uniform loading or a working day other than 10 hours is involved, a service factor f_D should be applied to the selection power or torque which is taken from table 2. High numbers of starts per hour also influence the mechanical

selection. Table 3 shows the starts factor f_s which should also be applied to the selection power or torque.

For guidance a comprehensive list of the various load conditions for a number of applications is given in Table 1. When confirming the mechanical selection powers therefore, the rating must be equal to or greater than calculated power or torque demand x application service factor f_D (table 1 and table 2) x starts factor f_s (table 3)

Efficiencies

The efficiency figures are approximate only and are those that could be expected from a gearbox which is fully run-in and operating under full load with the lubricant at its full working temperature.

For intermittent rating where the lubricant may remain comparatively cool, the efficiency may be somewhat lower due to the increased oil churning losses associated with the higher viscosity of the cool oil. We shall be pleased to advise on any particular application.

Thermal Rating

The thermal ratings given are those which the gear units will transmit at an ambient temperature of 20°C, when the heat generated within the gearbox is being dissipated at the same rate. Whilst these ratings can be exceeded under start up conditions, this situation could lead to overheating and subsequent damage if continuously applied. Thermal torque ratings do not relate to mechanical gear life and are not affected by running time or momentary shock loads.

If the ambient temperature is likely to exceed 20°C, this situation will have to be taken into account in the selection procedure. This is done by applying the thermal service factor given in table 4 when calculating the selection output torque.

E.g. Thermal selection torque = continuous torque requirement X thermal service factor f_t . Where intermittent running is involved it is possible the thermal limitation can be ignored, such as on a crane or winch application, and when this type of operation is being considered full applicational details should be given to Renold for assessment.

Selection Procedure**MOTORISED UNIT SELECTION PROCEDURE
PM SERIES MOTORISED**

To select a PM series motorised unit, the following procedure should be followed.

- a) Determine required output speed.
- b) Select the total Mechanical Service Factor f_D (table 2) and Starts Factor f_s (table 3)
Total Mechanical Service Factor = $f_D \times f_s$
- c) Determine the power absorbed by the machine.
Absorbed Power (kW) = $\frac{\text{Absorbed torque (Nm)} \times \text{Speed (RPM)}}{9550}$
- d) Select an electric motor that will give an output power greater than that of the absorbed power above.
- e) Select a gear unit from the tables on pages 19 - 31 using the motor power and the output speed as the basis. Ensure that the Mechanical service factor S_f of the unit selected exceeds the selection factor from b) above.

**NON-MOTORISED UNIT
SELECTION PROCEDURE**

When a non-motorised gear unit is under consideration proceed as follows:-

- a) Establish the ratio, input speed and input power or output torque required.
- b) Determine the Load Classification for the appropriate application from table 1 and the corresponding Service Factor from table 2. Multiply this by the factor for starts per hour in table 3. The input power or output torque in 1 must now be multiplied by this factor in order to establish the required mechanical rating. This value must be equal to or less than the Mechanical Rating listed against the appropriate rating and input speed shown on pages 38 - 51.
- c) Determine the Thermal Service factor from table 4 and multiply the input power or output torque in 1 by this figure. The Thermal Rating appropriate to the unit tentatively selected in 2 must be equal to or greater than this value.
- d) Where an output shaft is fitted, check that any Overhung and/or Axial loads applied are within the capabilities of the unit - see page 36.

RENOLD PM Series - Selection Examples

Mechanical Selection Torque	Nm =	Actual Torque (Nm) Requirement	X	Mechanical Service (fd) Factor	X	Starts (fs) Factors
Thermal Selection Torque	Nm =	Actual Torque (Nm) Requirement	X	Thermal Service (fr) Factor		
Mechanical Selection Power	(kW) =	Actual Power (kW) Requirement	X	Mechanical Service (fd) Factor	X	Starts (fs) Factor
Thermal Selection Power	(kW) =	Actual Power (kW) Requirement	X	Thermal Service (fr) Factor		

It can be seen from the ratings tables on pages 38 - 51 that both mineral and synthetic oil ratings are included. Depending upon which type of oil is to be used inside the gear unit will determine which rating are used to make a selection.

Example 1 (Motorised Unit)

A motorised gear unit is required to drive a belt conveyor carrying ungraded stone resulting in uneven loading conditions. The torque required at the headshaft is nominally 3000 Nm at 50 rev/min, operating for 10 hours each day. A shaft mounted geared motor is required together with horizontal output flange restraint for bolting directly onto the conveyor support structure.

a) Approximate motor power (kW)

$$= \frac{3000 \times 50}{9550} = 15.70 \text{ kW}$$

Nearest larger motor power is 18.5 kW.

b) From the Load Classification and Service Factor tables 1 and 2, for a medium impulsive drive operating 10 hours per day, a Duty Service Factor of 1.25 is derived.

c) From the capacity tables on page 29 it can be seen that a size PW80 PM Series complete with an 18.5 kW electric motor has a mechanical service factor (fm) of 1.25. The PW80 unit is the correct selection.

Motorised Unit Inertia WR² (kgm²)

Total input

$$\text{Shaft Inertia} = \text{motor inertia} + \text{coupling inertia} + \text{input shaft inertia}$$
(page 10) (page 14) (page 14)

Total hollow Output shaft =

$$\text{Hollow output shaft inertia}$$
(page 20)

Total plug-in Output shaft Inertia =

$$\text{Hollow output shaft inertia} + \text{Plug-in output shaft inertia}$$
(page 14) (page 14)

Example 2 (Non-Motorised)

A right angle shaft gearbox is required to drive a hoist drum. The gear unit is to be driven by an electric motor, the connection to the drum being by a 3/1 chain reduction. The output shaft extension is to the right of the gear unit when viewed from the input shaft. The maximum raised load is 1950 kg, drum 0.5 metres diameter rotating at 10 rev/min. The chain pinion has a pitch diameter of 10,064" (255,6 mm).

Service is intermittent, 30 cycles each hour with an operating cycle of 1 minute raise/1 minute lower.

Power of motor to be decided, motor speed 1440 rev/min. (1500 rev/min)

a) Torque at drum

$$= \frac{1950 \times 0.5}{2} = 487.5 \text{ kgm}$$

In Newton meters

$$= 487.5 \times 9.8 = 4777.5 \text{ Nm}$$

Torque at output shaft of gear unit

$$= \frac{4777.5}{3} = 1592.5 \text{ Nm}$$

Output speed from gear unit

$$= 10 \times 3 = 30 \text{ rev/min}$$

Gear ratio

$$= \frac{1440}{30} = 48/1$$

b) Load Classification from table 1 indicates medium impulsive duty.

From table 2 this equates to a service factor 1.25.
 Factor for starts/hour from table 3 is 1.30.

Mechanical selection torque

$$= 1592.5 \times 1.25 \times 1.30 = 2588 \text{ Nm}$$

The thermal selection torque uses the thermal factor from table 4. (Assuming ambient temperature of 20°C).

Thermal service factor (ft) = 1.0

Thermal selection = 1592.5 x 1.0

Torque = 15.92.5 Nm

c) The closest gear ratio to 48/1 is 50/1, see ratio tables on pages 38 - 51. From the capacity tables on pages 49 the 50/1 ratio table shows that the PW70 unit will transmit both the mechanical and thermal selection torques. Lubrication in this example is by mineral oil.

d) To check radial pull on on output shaft from chain drive

Output torque = 1592.5 Nm

Chain pull

$$= \frac{1592.5 \times 2}{0.2556} = 12460 \text{ Newtons}$$

The overhung load capacities for the speed reducer unit can be found on page 36 and at an input speed of 1500 rev/min nominal and at 50/1 ratio it can be found that the PW70 unit is capable of supporting the overhung load of 12460 N.

Motorised Unit Inertia WR² (kgm²)

Total input Shaft Inertia =

$$\text{Input Shaft Inertia} + \text{Coupling Inertia}$$
(page 14)

Total Hollow Output Shaft Inertia =

$$\text{Hollow Output Shaft Inertia}$$
(page 14)

Total Plug-in Output Shaft Inertia =

$$\text{Hollow Output Shaft Inertia} + \text{Plug-in Output Shaft Inertia}$$
(page 14) (page 14)

Unit Inertia WR²

Unit WR² value with respect to the input =

$$\text{Input shaft value} + \left[\frac{\text{output shaft value}}{\text{actual ratio}^2} \right]$$

Unit WR² value with respect to output =

$$\text{Output shaft value} + \left[\frac{\text{input shaft value}}{\text{actual ratio}^2} \right]$$

Actual ratios see page 37.

RENOLD PM Series - Overhung and Thrust Loads

Output shafts of worm gear units are frequently fitted with a spur pinion, chain pinion or belt pulley causing an overhung load to be imposed on the output shaft and bearings. These loads can generally be sustained by the gear unit; however, if the load is greater than the maximum allowable load for the unit, it may be necessary to either select a larger unit or to lessen the effect of the load on the shaft bearings. This can be done in two ways. The pinion can be mounted on a shaft in its own bearings and the shaft coupled to the gear unit; or the wheel shaft may be extended beyond the overhung load and fitted with an outboard bearing. In order to obtain the best possible arrangement for a particular application (where large over hung loads are anticipated) customers are advised to submit details of the load to our Sales Technical Staff for their consideration.

In the interests of good design, the overhung member should be fitted as close as possible to the gear case in order to minimise the stresses and reduce the deflecting moment on the unit.

The maximum imposed axial thrust and overhung loads to which the units can be subjected are given in pages 19 - 31 and 36 .

Imposed axial thrust loads can also be minimised by the use of flexible couplings on the input and output shafts.

For drives where both imposed thrust and overhung loads are encountered, it is advisable to consult our Technical Sales Staff.

The overhung load may be calculated by the following formula:

$$\frac{9.55P \times 10^6 \times F \text{ (Newtons)}}{R \times S}$$

Where P = Power absorbed at output shaft (kW)

S = Speed of output shaft in rev/min

R = Pitch circle radius of chain pinion, spur or helical gear, or belt pulley in mm.

F = Overhung drive application factor as follows:

Chain pinion 1.00

Spur or helical gear 1.25

Vee pulley 1.50

Flat belt pulley 2.00

The overhung load capacities listed in table 5 assume the load is applied mid-way along the output shaft extension, the relevant dimension from the centre line of the unit being as given below.

Unit Size	X
PW35	165
PW40	175
PW50	210
PW60	235
PW70	270
PW80	270

- based on Single Extension Plug-in Shaft

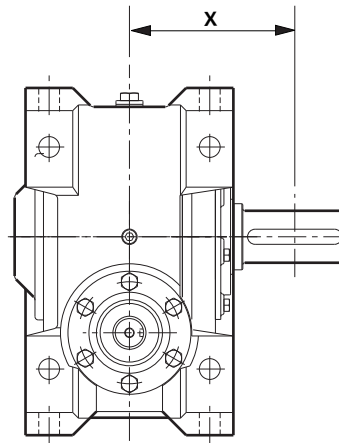

RENOLD PM Series - PW Type - Motorised - Selection Data

P₁ 0.55 kW		4P - D80KD 1365 RPM					6P - D80GD 900 RPM						
n₂	Actual	M₂	S_F	Overhung	Axial	Product Code	n₂	Actual	M₂	S_F	Overhung	Axial	Product Code
rpm	Ratio	Nm		Load	Load		rpm	Ratio	Nm		Load	Load	
	i			(max.) N	(max.) N					(max.) N	(max.) N		
	264.2	5.17	17	23.37	9000	16000	PW305D4P005***						
*	176.1	7.75	26	18.66	9000	16000	PW307D4P005***						
	132.1	10.33	34	15.14	9000	16000	PW310D4P005***						
*	113.8	12.00	39	13.40	9000	16000	PW312D4P005***						
	88.1	15.50	49	10.86	9000	16000	PW315D4P005***						
	68.3	20.00	61	9.31	9000	16000	PW320D4P005***						
	54.6	25.00	75	8.15	9000	16000	PW325D4P005***						
	45.5	30.00	87	6.59	9000	16000	PW330D4P005***						
*	39.0	35.00	100	5.57	9000	16000	PW335D4P005***						
	34.1	40.00	112	4.73	9000	16000	PW340D4P005***						
*	30.3	45.00	125	4.09	9000	16000	PW345D4P005***						
	27.9	49.00	134	3.62	9000	16000	PW350D4P005***						
	25.7	35.00	151	4.21	9000	16000	PW335D6P005***						
	22.8	60.00	156	2.76	9000	16000	PW360D4P005***						
	19.5	70.00	171	3.44	18000	20000	PW470D4P005***						
	19.5	70.00	176	2.34	9000	16000	PW370D4P005***						
	18.4	49.00	200	2.79	9000	16000	PW350D6P005***						
	15.0	60.00	237	3.14	18000	20000	PW460D6P005***						
	15.0	60.00	232	2.13	9000	16000	PW360D6P005***						
	12.9	70.00	258	2.61	18000	20000	PW470D6P005***						
	12.9	70.00	262	1.74	9000	16000	PW370D6P005***						

Key

- n₂ Output Speed, rpm
- i Overall Ratio
- M₂ Output Torque Nm, Mechanical
- S_F Service Factor, Mechanical

* - This ratio made to order

For details of unit designation code see page 13.

The overhung load shown above is based on the maximum motor Power being transmitted. For higher overhung loads consult Renold.

P₁ 0.75 kW		4P - D80GD 1345 RPM					6P - D90SD 910 RPM						
n₂	Actual	M₂	S_F	Overhung	Axial	Product Code	n₂	Actual	M₂	S_F	Overhung	Axial	Product Code
rpm	Ratio	Nm		Load	Load		rpm	Ratio	Nm		Load	Load	
	i			(max.) N	(max.) N					(max.) N	(max.) N		
	260.3	5.17	24	16.56	9000	16000	PW305D4P007***						
*	173.5	7.75	36	13.21	9000	16000	PW307D4P007***						
	130.2	10.33	48	10.75	9000	16000	PW310D4P007***						
*	112.1	12.00	55	9.52	9000	16000	PW312D4P007***						
	86.8	15.50	70	7.72	9000	16000	PW315D4P007***						
	67.3	20.00	86	6.61	9000	16000	PW320D4P007***						
	53.8	25.00	106	5.79	9000	16000	PW325D4P007***						
	44.8	30.00	123	4.69	9000	16000	PW330D4P007***						
*	38.4	35.00	142	3.96	9000	16000	PW335D4P007***						
	33.6	40.00	159	3.35	9000	16000	PW340D4P007***						
*	29.9	45.00	177	2.90	9000	16000	PW345D4P007***						
	27.4	49.00	189	2.57	9000	16000	PW350D4P007***						
	22.4	60.00	224	2.91	18000	20000	PW460D4P007***						
	22.4	60.00	220	1.96	9000	16000	PW360D4P007***						
*	20.2	45.00	259	3.33	18000	20000	PW445D6P007***						
*	20.2	45.00	256	2.27	9000	16000	PW345D6P007***						
	19.2	70.00	245	2.41	18000	20000	PW470D4P007***						
	19.2	70.00	250	1.66	9000	16000	PW370D4P007***						
	18.6	49.00	275	2.03	9000	16000	PW350D6P007***						
	18.2	50.00	282	2.92	18000	20000	PW450D6P007***						
	15.2	60.00	323	4.15	25000	35000	PW560D6P007***						
	15.2	60.00	328	2.26	18000	20000	PW460D6P007***						
	15.2	60.00	318	1.55	9000	16000	PW360D6P007***						
	13.0	70.00	353	3.42	25000	35000	PW570D6P007***						
	13.0	70.00	357	1.89	18000	20000	PW470D6P007***						
	13.0	70.00	360	1.27	9000	16000	PW370D6P007***						



Units to ATEX approval must be selected with a minimum service factor of 1.25.

IMPORTANT

RENOLD PM Series - PW Type - Motorised - Selection Data

P₁ 1.1 kW		4P - D90SD 1380 RPM					6P - D90LD 910 RPM					
n₂	Actual	M₂	S_F	Overhung	Axial	Product Code						
rpm	Ratio	Nm		Load	Load							
	i			(max.) N	(max.) N							
	267.1	5.17	36	11.20	9000	16000	PW305D4P011***					
*	178.1	7.75	53	8.99	9000	16000	PW307D4P011***					
	133.5	10.33	70	7.32	9000	16000	PW310D4P011***					
*	115.0	12.00	80	6.48	9000	16000	PW312D4P011***					
	89.0	15.50	102	5.24	9000	16000	PW315D4P011***					
*	75.8	12.00	121	5.06	9000	16000	PW312D6P011***					
	69.0	20.00	125	4.50	9000	16000	PW320D4P011***					
	55.2	25.00	154	3.94	9000	16000	PW325D4P011***					
	46.0	30.00	180	3.18	9000	16000	PW330D4P011***					
*	39.4	35.00	206	2.69	9000	16000	PW335D4P011***					
	36.4	25.00	230	3.05	9000	16000	PW325D6P011***					
	34.5	40.00	234	3.37	18000	20000	PW440D4P011***					
	34.5	40.00	232	2.28	9000	16000	PW340D4P011***					
*	30.7	45.00	259	2.90	18000	20000	PW445D4P011***					
*	30.7	45.00	258	1.98	9000	16000	PW345D4P011***					
	30.3	30.00	267	2.47	9000	16000	PW330D6P011***					
	27.6	50.00	283	2.53	18000	20000	PW450D4P011***					
	28.2	49.00	276	1.75	9000	16000	PW350D4P011***					
*	26.0	35.00	307	2.06	9000	16000	PW335D6P011***					
	23.0	60.00	324	3.62	25000	35000	PW560D4P011***					
	23.0	60.00	330	1.96	18000	20000	PW460D4P011***					
	23.0	60.00	322	1.33	9000	16000	PW360D4P011***					
	19.7	70.00	358	2.94	25000	35000	PW570D4P011***					
	19.7	70.00	362	1.61	18000	20000	PW470D4P011***					
	19.7	70.00	365	1.12	9000	16000	PW370D4P011***					
	18.6	49.00	408	1.36	9000	16000	PW350D6P011***					
	18.2	50.00	420	3.51	25000	35000	PW550D6P011***					
	18.2	50.00	422	1.95	18000	20000	PW450D6P011***					
	15.2	60.00	489	2.74	25000	35000	PW560D6P011***					
	15.2	60.00	490	1.51	18000	20000	PW460D6P011***					
	15.2	60.00	473	1.04	9000	16000	PW360D6P011***					
	13.0	70.00	535	2.25	25000	35000	PW570D6P011***					
	13.0	70.00	536	1.26	18000	20000	PW470D6P011***					
	13.0	70.00	536	0.85	9000	16000	PW370D6P011***					

The overhung load shown above is based on the maximum motor Power being transmitted. For higher overhung loads consult Renold.



IMPORTANT

Units to ATEX approval must be selected with a minimum service factor of 1.25.

- Key**
- n₂ Output Speed, rpm
 - i Overall Ratio
 - M₂ Output Torque Nm, Mechanical
 - S_F Service Factor, Mechanical

* - This ratio made to order
 For details of unit designation code see page 13.

RENOLD PM Series - PW Type - Motorised - Selection Data

P_1 1.5 kW		4P - D90LD 1370 RPM				
		6P - D100LD 935 RPM				
n_2	Actual Ratio	M_2	S_F	Overhung Load	Axial Load	Product Code
rpm	i	Nm		(max.) N	(max.) N	
265.2	5.17	50	8.09	9000	16000	PW305D4P015***
* 176.8	7.75	74	6.48	9000	16000	PW307D4P015***
132.6	10.33	97	5.28	9000	16000	PW310D4P015***
* 114.2	12.00	111	4.67	9000	16000	PW312D4P015***
88.4	15.50	141	3.79	9000	16000	PW315D4P015***
* 77.9	12.00	161	3.74	9000	16000	PW312D6P015***
68.5	20.00	174	3.25	9000	16000	PW320D4P015***
60.3	15.50	205	2.97	9000	16000	PW315D6P015***
54.8	25.00	214	2.85	9000	16000	PW325D4P015***
45.7	30.00	256	3.75	18000	20000	PW430D4P015***
45.7	30.00	250	2.30	9000	16000	PW330D4P015***
* 39.1	35.00	292	2.92	18000	20000	PW435D4P015***
* 39.1	35.00	287	1.94	9000	16000	PW335D4P015***
34.3	40.00	326	2.42	18000	20000	PW440D4P015***
34.3	40.00	322	1.65	9000	16000	PW340D4P015***
* 30.4	45.00	361	3.83	25000	35000	PW545D4P015***
* 30.4	45.00	361	2.08	18000	20000	PW445D4P015***
* 30.4	45.00	358	1.43	9000	16000	PW345D4P015***
28.0	49.00	384	1.26	9000	16000	PW350D4P015***
27.4	50.00	392	3.32	25000	35000	PW550D4P015***
27.4	50.00	395	1.81	18000	20000	PW450D4P015***
22.8	60.00	458	2.57	25000	35000	PW560D4P015***
22.8	60.00	460	1.41	18000	20000	PW460D4P015***
22.8	60.00	447	0.96	9000	16000	PW360D4P015***
* 20.8	45.00	525	2.96	25000	35000	PW545D6P015***
* 20.8	45.00	520	1.64	18000	20000	PW445D6P015***
* 20.8	45.00	510	1.13	9000	16000	PW345D6P015***
19.6	70.00	505	2.09	25000	35000	PW570D4P015***
19.6	70.00	506	1.16	18000	20000	PW470D4P015***
19.6	70.00	507	0.81	9000	16000	PW370D4P015***
19.1	49.00	547	1.01	9000	16000	PW350D6P015***
18.7	50.00	568	2.57	25000	35000	PW550D6P015***
18.7	50.00	568	1.44	18000	20000	PW450D6P015***
15.6	60.00	656	3.25	34000	50000	PW660D6P015***
15.6	60.00	662	2.00	25000	35000	PW560D6P015***
15.6	60.00	659	1.12	18000	20000	PW460D6P015***
13.4	70.00	722	2.68	34000	50000	PW670D6P015***
13.4	70.00	726	1.65	25000	35000	PW570D6P015***
13.4	70.00	721	0.93	18000	20000	PW470D6P015***

The overhung load shown above is based on the maximum motor Power being transmitted. For higher overhung loads consult Renold.



IMPORTANT

Units to ATEX approval must be selected with a minimum service factor of 1.25.

Key

- n_2 Output Speed, rpm
- i Overall Ratio
- M_2 Output Torque Nm, Mechanical
- S_F Service Factor, Mechanical

* - This ratio made to order

For details of unit designation code see page 13.

P₁ 2.2 kW						
4P - D100LD 1430 RPM						
6P - D112MD 945 RPM						
n₂	Actual	M₂	S_F	Overhung	Axial	Product Code
rpm	Ratio	Nm		Load	Load	
	i			(max.) N	(max.) N	
276.8	5.17	70	5.57	9000	16000	PW305D4P022***
* 184.5	7.75	105	4.49	9000	16000	PW307D4P022***
138.4	10.33	138	3.66	9000	16000	PW310D4P022***
* 119.2	12.00	157	3.23	9000	16000	PW312D4P022***
92.3	15.50	201	2.62	9000	16000	PW315D4P022***
71.5	20.00	247	2.25	9000	16000	PW320D4P022***
69.8	20.50	262	2.74	18000	20000	PW420D4P022***
61.0	15.50	304	2.93	18000	20000	PW415D6P022***
61.0	15.50	300	2.03	9000	16000	PW315D6P022***
57.2	25.00	307	2.79	18000	20000	PW425D4P022***
57.2	25.00	304	1.98	9000	16000	PW325D4P022***
47.7	30.00	365	2.59	18000	20000	PW430D4P022***
47.7	30.00	355	1.59	9000	16000	PW330D4P022***
* 40.9	35.00	417	3.68	25000	35000	PW535D4P022***
* 40.9	35.00	416	2.02	18000	20000	PW435D4P022***
* 40.9	35.00	408	1.35	9000	16000	PW335D4P022***
35.8	40.00	468	3.04	25000	35000	PW540D4P022***
35.8	40.00	465	1.67	18000	20000	PW440D4P022***
35.8	40.00	458	1.14	9000	16000	PW340D4P022***
* 31.8	45.00	520	2.62	25000	35000	PW545D4P022***
* 31.8	45.00	516	1.44	18000	20000	PW445D4P022***
* 31.8	45.00	508	0.99	9000	16000	PW345D4P022***
29.2	49.00	546	0.88	9000	16000	PW350D4P022***
28.6	50.00	559	3.70	34000	50000	PW650D4P022***
28.6	50.00	565	2.27	25000	35000	PW550D4P022***
28.6	50.00	565	1.26	18000	20000	PW450D4P022***
23.8	60.00	653	2.86	34000	50000	PW660D4P022***
23.8	60.00	659	1.76	25000	35000	PW560D4P022***
23.8	60.00	658	0.97	18000	20000	PW460D4P022***
20.4	70.00	723	2.30	34000	50000	PW670D4P022***
20.4	70.00	729	1.41	25000	35000	PW570D4P022***
20.4	70.00	725	0.79	18000	20000	PW470D4P022***
15.8	60.00	976	2.18	34000	50000	PW660D6P022***
15.8	60.00	976	1.35	25000	35000	PW560D6P022***
13.5	70.00	1075	1.80	34000	50000	PW670D6P022***
13.5	70.00	1072	1.11	25000	35000	PW570D6P022***

The overhung load shown above is based on the maximum motor Power being transmitted. For higher overhung loads consult Renold.



IMPORTANT

Units to ATEX approval must be selected with a minimum service factor of 1.25.

Key

- n₂ Output Speed, rpm
- i Overall Ratio
- M₂ Output Torque Nm, Mechanical
- S_F Service Factor, Mechanical

* - This ratio made to order

For details of unit designation code see page 13.

RENOLD PM Series - PW Type - Motorised - Selection Data

P_i 3.0 kW						
4P - D100LXD 1400 RPM						
6P - D132MD 960 RPM						
n₂	Actual	M₂	S_F	Overhung	Axial	Product Code
	Ratio			Load	Load	
rpm	i	Nm		(max.) N	(max.) N	
271.0	5.17	99	4.01	9000	16000	PW305D4P030***
* 180.6	7.75	147	3.23	9000	16000	PW307D4P030***
144.8	9.67	181	3.22	18000	20000	PW410D4P030***
135.5	10.33	193	2.63	9000	16000	PW310D4P030***
* 116.7	12.00	220	2.33	9000	16000	PW312D4P030***
* 113.5	12.33	229	2.94	18000	20000	PW412D4P030***
92.9	10.33	279	2.11	9000	16000	PW310D6P030***
90.3	15.50	283	2.74	18000	20000	PW415D4P030***
90.3	15.50	281	1.89	9000	16000	PW315D4P030***
* 80.0	12.00	318	1.88	9000	16000	PW312D6P030***
* 77.8	12.33	332	2.35	18000	20000	PW412D6P030***
70.0	20.00	345	1.62	9000	16000	PW320D4P030***
68.3	20.50	366	3.56	25000	35000	PW520D4P030***
68.3	20.50	367	1.96	18000	20000	PW420D4P030***
61.9	15.50	411	3.83	25000	35000	PW515D6P030***
61.9	15.50	410	2.15	18000	20000	PW415D6P030***
61.9	15.50	404	1.49	9000	16000	PW315D6P030***
57.1	24.50	432	2.86	25000	35000	PW525D4P030***
56.0	25.00	431	2.01	18000	20000	PW425D4P030***
56.0	25.00	425	1.42	9000	16000	PW325D4P030***
46.7	30.00	513	3.16	25000	35000	PW530D4P030***
46.7	30.00	513	1.86	18000	20000	PW430D4P030***
46.7	30.00	496	1.15	9000	16000	PW330D4P030***
* 40.0	35.00	588	2.63	25000	35000	PW535D4P030***
* 40.0	35.00	584	1.45	18000	20000	PW435D4P030***
* 40.0	35.00	570	0.97	9000	16000	PW335D4P030***
35.0	40.00	656	3.52	34000	50000	PW640D4P030***
35.0	40.00	660	2.18	25000	35000	PW540D4P030***
35.0	40.00	653	1.20	18000	20000	PW440D4P030***
35.0	40.00	640	0.82	9000	16000	PW340D4P030***
* 31.1	45.00	727	3.01	34000	50000	PW645D4P030***
* 31.1	45.00	732	1.88	25000	35000	PW545D4P030***
* 31.1	45.00	724	1.03	18000	20000	PW445D4P030***
28.0	50.00	794	2.63	34000	50000	PW650D4P030***
28.0	50.00	796	1.62	25000	35000	PW550D4P030***
28.0	50.00	792	0.90	18000	20000	PW450D4P030***
* 27.4	35.00	849	3.23	34000	50000	PW635D6P030***
* 27.4	35.00	845	2.06	25000	35000	PW535D6P030***
* 27.4	35.00	836	1.14	18000	20000	PW435D6P030***
23.3	60.00	928	2.04	34000	50000	PW660D4P030***
23.3	60.00	931	1.26	25000	35000	PW560D4P030***
* 21.3	45.00	1041	3.50	42000	55000	PW745D6P030***
* 21.3	45.00	1046	2.36	34000	50000	PW645D6P030***
* 21.3	45.00	1049	1.46	25000	35000	PW545D6P030***
* 21.3	45.00	1030	0.82	18000	20000	PW445D6P030***
20.0	70.00	1028	1.63	34000	50000	PW670D4P030***
20.0	70.00	1028	1.01	25000	35000	PW570D4P030***
16.0	60.00	1332	3.38	55000	55000	PW860D6P030***
16.0	60.00	1336	2.38	42000	55000	PW760D6P030***
16.0	60.00	1330	1.59	34000	50000	PW660D6P030***
16.0	60.00	1325	0.99	25000	35000	PW560D6P030***
13.7	70.00	1473	2.79	55000	55000	PW870D6P030***
13.7	70.00	1477	1.96	42000	55000	PW770D6P030***
13.7	70.00	1464	1.31	34000	50000	PW670D6P030***
13.7	70.00	1456	0.81	25000	35000	PW570D6P030***

The overhung load shown above is based on the maximum motor Power being transmitted. For higher overhung loads consult Renold.



IMPORTANT

Units to ATEX approval must be selected with a minimum service factor of 1.25.

Key

- n₂ Output Speed, rpm
- i Overall Ratio
- M₂ Output Torque Nm, Mechanical
- S_F Service Factor, Mechanical
- * - This ratio made to order

For details of unit designation code see page 13.

RENOLD PM Series - PW Type - Motorised - Selection Data

P₁ 4.0 kW		4P - D112MD 1430 RPM					6P - D132MD 955 RPM				
n₂	Actual Ratio	M₂	S_F	Overhung Load	Axial Load	Product Code					
rpm	i	Nm		(max.) N	(max.) N						
276.8	5.17	129	3.03	9000	16000	PW305D4P040***					
* 197.2	7.25	180	2.86	18000	20000	PW407D4P040***					
* 184.5	7.75	192	2.45	9000	16000	PW307D4P040***					
147.9	9.67	237	4.16	25000	35000	PW510D4P040***					
147.9	9.67	238	2.44	18000	20000	PW410D4P040***					
138.4	10.33	253	2.00	9000	16000	PW310D4P040***					
* 119.2	12.00	289	1.76	9000	16000	PW312D4P040***					
* 115.9	12.33	299	4.00	25000	35000	PW512D4P040***					
* 115.9	12.33	300	2.22	18000	20000	PW412D4P040***					
92.3	15.50	372	3.67	25000	35000	PW515D4P040***					
92.3	15.50	372	2.07	18000	20000	PW415D4P040***					
92.3	15.50	368	1.43	9000	16000	PW315D4P040***					
* 79.6	12.00	427	1.40	9000	16000	PW312D6P040***					
* 77.4	12.33	447	3.15	25000	35000	PW512D6P040***					
* 77.4	12.33	447	1.75	18000	20000	PW412D6P040***					
71.5	20.00	453	1.23	9000	16000	PW320D4P040***					
69.8	20.50	482	2.68	25000	35000	PW520D4P040***					
69.8	20.50	482	1.49	18000	20000	PW420D4P040***					
61.6	15.50	554	2.85	25000	35000	PW515D6P040***					
61.6	15.50	551	1.61	18000	20000	PW415D6P040***					
61.6	15.50	543	1.11	9000	16000	PW315D6P040***					
58.4	24.50	566	3.51	34000	50000	PW625D4P040***					
58.4	24.50	569	2.15	25000	35000	PW525D4P040***					
57.2	25.00	566	1.52	18000	20000	PW425D4P040***					
57.2	25.00	557	1.08	9000	16000	PW325D4P040***					
47.7	30.00	674	3.48	34000	50000	PW630D4P040***					
47.7	30.00	676	2.39	25000	35000	PW530D4P040***					
47.7	30.00	674	1.40	18000	20000	PW430D4P040***					
47.7	30.00	651	0.87	9000	16000	PW330D4P040***					
* 40.9	35.00	776	3.10	34000	50000	PW635D4P040***					
* 40.9	35.00	775	1.98	25000	35000	PW535D4P040***					
* 40.9	35.00	768	1.09	18000	20000	PW435D4P040***					
35.8	40.00	869	2.64	34000	50000	PW640D4P040***					
35.8	40.00	870	1.64	25000	35000	PW540D4P040***					
35.8	40.00	858	0.91	18000	20000	PW440D4P040***					
* 31.8	45.00	962	2.25	34000	50000	PW645D4P040***					
* 31.8	45.00	965	1.41	25000	35000	PW545D4P040***					
* 31.8	45.00	951	0.78	18000	20000	PW445D4P040***					
28.6	50.00	1051	1.97	34000	50000	PW650D4P040***					
28.6	50.00	1050	1.22	25000	35000	PW550D4P040***					
* 27.3	35.00	1151	3.44	42000	55000	PW735D6P040***					
* 27.3	35.00	1148	2.39	34000	50000	PW635D6P040***					
* 27.3	35.00	1140	1.53	25000	35000	PW535D6P040***					
* 27.3	35.00	1124	0.85	18000	20000	PW435D6P040***					
23.9	40.00	1291	3.05	42000	55000	PW740D6P040***					
23.9	40.00	1282	2.04	34000	50000	PW640D6P040***					
23.9	40.00	1275	1.26	25000	35000	PW540D6P040***					
23.8	60.00	1229	1.52	34000	50000	PW660D4P040***					
23.8	60.00	1226	0.95	25000	35000	PW560D4P040***					
* 21.2	45.00	1411	2.59	42000	55000	PW745D6P040***					
* 21.2	45.00	1415	1.74	34000	50000	PW645D6P040***					
* 21.2	45.00	1413	1.09	25000	35000	PW545D6P040***					
20.4	70.00	1363	1.22	34000	50000	PW670D4P040***					
19.1	50.00	1552	3.22	55000	55000	PW850D6P040***					
19.1	50.00	1552	2.27	42000	55000	PW750D6P040***					
19.1	50.00	1544	1.52	34000	50000	PW650D6P040***					
19.1	50.00	1534	0.95	25000	35000	PW550D6P040***					
15.9	60.00	1814	2.49	55000	55000	PW860D6P040***					
15.9	60.00	1812	1.76	42000	55000	PW760D6P040***					
15.9	60.00	1800	1.18	34000	50000	PW660D6P040***					
13.6	70.00	2007	2.05	55000	55000	PW870D6P040***					
13.6	70.00	2002	1.45	42000	55000	PW770D6P040***					
13.6	70.00	1982	0.97	34000	50000	PW670D6P040***					

The overhung load shown above is based on the maximum motor Power being transmitted. For higher overhung loads consult Renold.



IMPORTANT

Units to ATEX approval must be selected with a minimum service factor of 1.25.

- Key**
- n₂ Output Speed, rpm
 - i Overall Ratio
 - M₂ Output Torque Nm, Mechanical
 - S_F Service Factor, Mechanical
- * - This ratio made to order

For details of unit designation code see page 13.

RENOLD PM Series - PW Type - Motorised - Selection Data

P ₁ 5.5 kW						
4P - D132SD 1435 RPM						
6P - D132MXD 955 RPM						
n ₂	Actual	M ₂	S _F	Overhung	Axial	Product Code
rpm	Ratio			Load	Load	
	i	Nm		(max.) N	(max.) N	
277.7	5.17	178	2.80	18000	20000	PW405D4P055***
277.7	5.17	178	2.19	9000	16000	PW305D4P055***
* 197.9	7.25	247	3.49	25000	35000	PW507D4P055***
* 197.9	7.25	248	2.07	18000	20000	PW407D4P055***
* 185.2	7.75	264	1.78	9000	16000	PW307D4P055***
148.4	9.67	327	3.00	25000	35000	PW510D4P055***
148.4	9.67	328	1.77	18000	20000	PW410D4P055***
138.9	10.33	347	1.45	9000	16000	PW310D4P055***
* 119.6	12.00	397	1.28	9000	16000	PW312D4P055***
* 116.4	12.33	413	2.90	25000	35000	PW512D4P055***
* 116.4	12.33	413	1.61	18000	20000	PW412D4P055***
92.6	15.50	513	2.66	25000	35000	PW515D4P055***
92.6	15.50	512	1.50	18000	20000	PW415D4P055***
92.6	15.50	505	1.04	9000	16000	PW315D4P055***
* 78.0	12.25	615	3.54	34000	50000	PW612D6P055***
* 77.4	12.33	617	2.28	25000	35000	PW512D6P055***
* 77.4	12.33	616	1.27	18000	20000	PW412D6P055***
71.8	20.00	623	0.89	9000	16000	PW320D4P055***
70.0	20.50	664	3.12	34000	50000	PW620D4P055***
70.0	20.50	666	1.94	25000	35000	PW520D4P055***
70.0	20.50	663	1.08	18000	20000	PW420D4P055***
65.1	14.67	729	3.15	34000	50000	PW615D6P055***
61.6	15.50	765	2.06	25000	35000	PW515D6P055***
61.6	15.50	760	1.16	18000	20000	PW415D6P055***
61.6	15.50	748	0.81	9000	16000	PW315D6P055***
58.6	24.50	784	2.53	34000	50000	PW625D4P055***
58.6	24.50	785	1.56	25000	35000	PW525D4P055***
57.4	25.00	780	1.10	18000	20000	PW425D4P055***
57.4	25.00	766	0.78	9000	16000	PW325D4P055***
47.8	30.00	933	2.51	34000	50000	PW630D4P055***
47.8	30.00	933	1.73	25000	35000	PW530D4P055***
47.8	30.00	928	1.02	18000	20000	PW430D4P055***
* 41.0	35.00	1076	3.19	42000	55000	PW735D4P055***
* 41.0	35.00	1075	2.23	34000	50000	PW635D4P055***
* 41.0	35.00	1070	1.43	25000	35000	PW535D4P055***
* 41.0	35.00	1057	0.79	18000	20000	PW435D4P055***
35.9	40.00	1211	2.81	42000	55000	PW740D4P055***
35.9	40.00	1203	1.90	34000	50000	PW640D4P055***
35.9	40.00	1200	1.18	25000	35000	PW540D4P055***
* 31.9	45.00	1331	3.42	55000	55000	PW845D4P055***
* 31.9	45.00	1327	2.39	42000	55000	PW745D4P055***

P ₁ 5.5 kW (cont)						
4P - D132SD 1435 RPM						
6P - D132MXD 955 RPM						
n ₂	Actual	M ₂	S _F	Overhung	Axial	Product Code
rpm	Ratio			Load	Load	
	i	Nm		(max.) N	(max.) N	
* 31.9	45.00	1332	1.62	34000	50000	PW645D4P055***
* 31.9	45.00	1332	1.02	25000	35000	PW545D4P055***
28.7	50.00	1459	2.99	55000	55000	PW850D4P055***
28.7	50.00	1462	2.10	42000	55000	PW750D4P055***
28.7	50.00	1457	1.42	34000	50000	PW650D4P055***
28.7	50.00	1449	0.88	25000	35000	PW550D4P055***
23.9	60.00	1711	2.32	55000	55000	PW860D4P055***
23.9	60.00	1713	1.64	42000	55000	PW760D4P055***
23.9	60.00	1704	1.10	34000	50000	PW660D4P055***
23.9	40.00	1762	0.91	24700	35000	PW540D6P055***
* 21.2	45.00	1977	2.65	55000	55000	PW845D6P055***
* 21.2	45.00	1960	1.86	42000	55000	PW745D6P055***
* 21.2	45.00	1960	1.26	34000	50000	PW645D6P055***
* 21.2	45.00	1953	0.79	23100	35000	PW545D6P055***
20.5	70.00	1904	1.85	55000	55000	PW870D4P055***
20.5	70.00	1906	1.30	42000	55000	PW770D4P055***
20.5	70.00	1891	0.88	34000	50000	PW670D4P055***
19.1	50.00	2161	2.31	55000	55000	PW850D6P055***
19.1	50.00	2153	1.63	42000	55000	PW750D6P055***
19.1	50.00	2137	1.10	34000	50000	PW650D6P055***
15.9	60.00	2524	1.79	55000	55000	PW860D6P055***
15.9	60.00	2514	1.27	42000	55000	PW760D6P055***
15.9	60.00	2491	0.85	30900	50000	PW660D6P055***
13.6	70.00	2799	1.47	55000	55000	PW870D6P055***
13.6	70.00	2783	1.04	41500	55000	PW770D6P055***

Key

- n₂ Output Speed, rpm
- i Overall Ratio
- M₂ Output Torque Nm, Mechanical
- S_F Service Factor, Mechanical

* - This ratio made to order

For details of unit designation code see page 13.

The overhung load shown above is based on the maximum motor Power being transmitted. For higher overhung loads consult Renold.



Units to ATEX approval must be selected with a minimum service factor of 1.25.

RENOLD PM Series - PW Type - Motorised - Selection Data

P₁ 7.5 kW		4P - D132SD 1435 RPM					6P - D160MD 965 RPM						
n₂	Actual Ratio	M₂	S_F	Overhung Load	Axial Load	Product Code	n₂	Actual Ratio	M₂	S_F	Overhung Load	Axial Load	Product Code
rpm	i	Nm		(max.) N	(max.) N		rpm	i	Nm		(max.) N	(max.) N	
277.7	5.17	243	3.60	25000	35000	PW505D4P075***							
277.7	5.17	243	2.04	18000	20000	PW405D4P075***							
277.7	5.17	243	1.61	9000	16000	PW305D4P075***							
* 197.9	7.25	339	2.55	25000	35000	PW507D4P075***							
* 197.9	7.25	339	1.51	18000	20000	PW407D4P075***							
* 185.2	7.75	361	1.30	9000	16000	PW307D4P075***							
	9.67	449	2.19	25000	35000	PW510D4P075***							
	9.67	449	1.29	18000	20000	PW410D4P075***							
	9.75	452	3.66	34000	50000	PW610D4P075***							
	10.33	474	1.06	9000	16000	PW310D4P075***							
* 119.6	12.00	543	0.94	9000	16000	PW312D4P075***							
* 117.1	12.25	564	3.29	34000	50000	PW612D4P075***							
* 116.4	12.33	566	2.12	25000	35000	PW512D4P075***							
* 116.4	12.33	566	1.18	18000	20000	PW412D4P075***							
	14.67	669	2.94	34000	50000	PW615D4P075***							
	15.50	704	1.94	25000	35000	PW515D4P075***							
	15.50	700	1.10	18000	20000	PW415D4P075***							
* 78.8	12.25	835	2.60	34000	50000	PW612D6P075***							
* 78.2	12.33	837	1.68	25000	35000	PW512D6P075***							
	20.50	912	3.31	42000	55000	PW720D4P075***							
	20.50	912	2.28	34000	50000	PW620D4P075***							
	20.50	912	1.42	25000	35000	PW520D4P075***							
	20.50	908	0.79	18000	20000	PW420D4P075***							
	14.67	989	3.48	42000	55000	PW715D6P075***							
	14.67	989	2.32	34000	50000	PW615D6P075***							
	15.50	1038	1.52	25000	35000	PW515D6P075***							
	24.50	1077	2.75	42000	55000	PW725D4P075***							
	24.50	1076	1.84	34000	50000	PW625D4P075***							
	24.50	1075	1.14	25000	35000	PW525D4P075***							
	25.00	1067	0.80	18000	20000	PW425D4P075***							
	29.50	1285	3.11	55000	55000	PW830D4P075***							
	29.50	1281	2.11	42000	55000	PW730D4P075***							
	30.00	1283	1.83	34000	50000	PW630D4P075***							
	30.00	1279	1.26	25000	35000	PW530D4P075***							
* 41.0	35.00	1483	3.22	55000	55000	PW835D4P075***							
* 41.0	35.00	1481	2.31	42000	55000	PW735D4P075***							
* 41.0	35.00	1476	1.63	34000	50000	PW635D4P075***							
* 41.0	35.00	1466	1.05	25000	35000	PW535D4P075***							
	40.00	1667	2.79	55000	55000	PW840D4P075***							
	40.00	1667	2.04	42000	55000	PW740D4P075***							
	40.00	1655	1.38	34000	50000	PW640D4P075***							

P₁ 7.5 kW (cont)		4P - D132SD 1435 RPM					6P - D160MD 965 RPM						
n₂	Actual Ratio	M₂	S_F	Overhung Load	Axial Load	Product Code	n₂	Actual Ratio	M₂	S_F	Overhung Load	Axial Load	Product Code
rpm	i	Nm		(max.) N	(max.) N		rpm	i	Nm		(max.) N	(max.) N	
	35.9	40.00	1645	0.86	25000	35000	PW540D4P075***						
* 31.9	45.00	1839	2.48	55000	55000	PW845D4P075***							
* 31.9	45.00	1828	1.73	42000	55000	PW745D4P075***							
* 31.9	45.00	1830	1.18	34000	50000	PW645D4P075***							
	28.7	50.00	2014	2.17	55000	55000	PW850D4P075***						
	28.7	50.00	2014	1.53	42000	55000	PW750D4P075***						
	28.7	50.00	2001	1.03	34000	50000	PW650D4P075***						
* 27.6	35.00	2182	2.51	55000	55000	PW835D6P075***							
* 27.6	35.00	2172	1.81	42000	55000	PW735D6P075***							
* 27.6	35.00	2159	1.27	34000	50000	PW635D6P075***							
* 27.6	35.00	2133	0.81	25000	35000	PW535D6P075***							
	24.1	40.00	2446	2.19	55000	55000	PW840D6P075***						
	24.1	40.00	2434	1.61	42000	55000	PW740D6P075***						
	24.1	40.00	2411	1.08	31600	50000	PW640D6P075***						
	23.9	60.00	2363	1.68	55000	55000	PW860D4P075***						
	23.9	60.00	2360	1.19	42000	55000	PW760D4P075***						
	23.9	60.00	2342	0.80	32300	50000	PW660D4P075***						
* 21.4	45.00	2692	1.94	55000	55000	PW845D6P075***							
* 21.4	45.00	2665	1.37	42000	55000	PW745D6P075***							
* 21.4	45.00	2662	0.92	29200	50000	PW645D6P075***							
	20.5	70.00	2634	1.34	55000	55000	PW870D4P075***						
	20.5	70.00	2627	0.95	42000	55000	PW770D4P075***						
	19.3	50.00	2943	1.69	55000	55000	PW850D6P075***						
	19.3	50.00	2928	1.20	40600	55000	PW750D6P075***						
	19.3	50.00	2902	0.81	34000	50000	PW650D6P075***						
	16.1	60.00	3442	1.31	55000	55000	PW860D6P075***						
	16.1	60.00	3420	0.93	37200	55000	PW760D6P075***						
	13.8	70.00	3813	1.08	55000	55000	PW870D6P075***						

Key

- n₂ Output Speed, rpm
- i Overall Ratio
- M₂ Output Torque Nm, Mechanical
- S_F Service Factor, Mechanical

* - This ratio made to order

For details of unit designation code see page 13.

The overhung load shown above is based on the maximum motor Power being transmitted. For higher overhung loads consult Renold.



IMPORTANT Units to ATEX approval must be selected with a minimum service factor of 1.25.

RENOLD PM Series - PW Type - Motorised - Selection Data

P₁ 11.0 kW		4P - D160MD 1450 RPM					6P - D160LD 970 RPM						
n₂	Actual	M₂	S_F	Overhung	Axial	Product Code	n₂	Actual	M₂	S_F	Overhung	Axial	Product Code
rpm	Ratio	Nm		Load	Load		rpm	Ratio	Nm		Load	Load	
	i			(max.) N	(max.) N						(max.) N	(max.) N	
	282.9	5.13	350	4.10	34000	50000	PW605D4P110***						
	280.6	5.17	354	2.46	25000	35000	PW505D4P110***						
*	200.0	7.25	495	1.73	25000	35000	PW507D4P110***						
*	195.9	7.40	504	3.04	34000	50000	PW607D4P110***						
	150.0	9.67	654	1.50	25000	35000	PW510D4P110***						
	148.7	9.75	660	3.64	42000	55000	PW710D4P110***						
	148.7	9.75	660	2.49	34000	50000	PW610D4P110***						
*	118.4	12.25	823	3.52	42000	55000	PW712D4P110***						
*	118.4	12.25	824	2.25	34000	50000	PW612D4P110***						
*	117.6	12.33	826	1.44	25000	35000	PW512D4P110***						
	98.9	14.67	977	3.00	42000	55000	PW715D4P110***						
	98.9	14.67	977	2.00	34000	50000	PW615D4P110***						
	93.5	15.50	1026	1.32	25000	35000	PW515D4P110***						
*	79.2	12.25	1223	3.90	55000	55000	PW812D6P110***						
*	79.2	12.25	1224	2.76	42000	55000	PW712D6P110***						
*	79.2	12.25	1224	1.77	34000	50000	PW612D6P110***						
	70.7	20.50	1332	3.00	55000	55000	PW820D4P110***						
	70.7	20.50	1335	2.24	42000	55000	PW720D4P110***						
	70.7	20.50	1332	1.55	34000	50000	PW620D4P110***						
	70.7	20.50	1329	0.97	25000	35000	PW520D4P110***						
	66.1	14.67	1453	3.31	55000	55000	PW815D6P110***						
	66.1	14.67	1453	2.37	42000	55000	PW715D6P110***						
	66.1	14.67	1450	1.58	34000	50000	PW615D6P110***						
	59.2	24.50	1576	2.65	55000	55000	PW825D4P110***						
	59.2	24.50	1578	1.87	42000	55000	PW725D4P110***						
	59.2	24.50	1573	1.26	34000	50000	PW625D4P110***						
	59.2	24.50	1567	0.78	25000	35000	PW525D4P110***						
	49.2	29.50	1885	2.11	55000	55000	PW830D4P110***						
	49.2	29.50	1876	1.44	42000	55000	PW730D4P110***						
	48.3	30.00	1876	1.25	34000	50000	PW630D4P110***						
	48.3	30.00	1865	0.86	25000	35000	PW530D4P110***						
	47.3	20.50	1978	2.37	55000	55000	PW820D6P110***						
	47.3	20.50	1976	1.75	42000	55000	PW720D6P110***						
	47.3	20.50	1969	1.21	34000	50000	PW620D6P110***						
*	41.4	35.00	2178	2.19	55000	55000	PW835D4P110***						
*	41.4	35.00	2170	1.58	42000	55000	PW735D4P110***						
*	41.4	35.00	2158	1.11	33900	50000	PW635D4P110***						
	39.6	24.50	2335	2.06	55000	55000	PW825D6P110***						
	39.6	24.50	2329	1.46	42000	55000	PW725D6P110***						
	39.6	24.50	2319	0.98	32400	50000	PW625D6P110***						
	36.3	40.00	2449	1.89	55000	55000	PW840D4P110***						

P₁ 11.0 kW (cont)		4P - D160MD 1450 RPM					6P - D160LD 970 RPM						
n₂	Actual	M₂	S_F	Overhung	Axial	Product Code	n₂	Actual	M₂	S_F	Overhung	Axial	Product Code
rpm	Ratio	Nm		Load	Load		rpm	Ratio	Nm		Load	Load	
				(max.) N	(max.) N						(max.) N	(max.) N	
	36.3	40.00	2440	1.39	42000	55000	PW740D4P110***						
	36.3	40.00	2420	0.94	31500	50000	PW640D4P110***						
	32.9	29.50	2792	1.64	55000	55000	PW830D6P110***						
	32.9	29.50	2767	1.12	42000	55000	PW730D6P110***						
	32.3	30.00	2752	0.98	28200	50000	PW630D6P110***						
*	32.2	45.00	2702	1.68	55000	55000	PW845D4P110***						
*	32.2	45.00	2680	1.18	42000	55000	PW745D4P110***						
*	32.2	45.00	2676	0.80	2900	50000	PW645D4P110***						
	29.0	50.00	2959	1.47	55000	55000	PW850D4P110***						
	29.0	50.00	2948	1.04	40400	55000	PW750D4P110***						
*	27.7	35.00	3210	1.71	55000	55000	PW835D6P110***						
*	27.7	35.00	3188	1.23	38800	55000	PW735D6P110***						
*	27.7	35.00	3161	0.87	23400	50000	PW635D6P110***						
	24.3	40.00	3600	1.48	55000	55000	PW840D6P110***						
	24.3	40.00	3574	1.10	36000	55000	PW740D6P110***						
	24.2	60.00	3473	1.14	55000	55000	PW860D4P110***						
	24.2	60.00	3456	0.81	36900	55000	PW760D4P110***						
*	21.6	45.00	3962	1.32	55000	55000	PW845D6P110***						
*	21.6	45.00	3913	0.93	33200	55000	PW745D6P110***						
	20.7	70.00	3869	0.91	55000	55000	PW870D4P110***						
	19.4	50.00	4326	1.15	55000	55000	PW850D6P110***						
	19.4	50.00	4299	0.82	30300	55000	PW750D6P110***						
	16.2	60.00	5062	0.89	52800	55000	PW860D6P110***						

Key

- n₂ Output Speed, rpm
- i Overall Ratio
- M₂ Output Torque Nm, Mechanical
- S_F Service Factor, Mechanical

* - This ratio made to order

For details of unit designation code see page 13.

The overhung load shown above is based on the maximum motor Power being transmitted. For higher overhung loads consult Renold.



Units to ATEX approval must be selected with a minimum service factor of 1.25.

P₁ 15.0 kW						
4P - D160LD 1460 RPM						
6P - D180LD 980 RPM						
n₂	Actual	M₂	S_F	Overhung	Axial	Product Code
	Ratio			Load	Load	
rpm	i	Nm		(max.) N	(max.) N	
284.9	5.13	476	3.01	34000	50000	PW605D4P150***
282.6	5.17	481	1.80	25000	35000	PW505D4P150***
* 201.4	7.25	672	1.27	25000	35000	PW507D4P150***
* 197.3	7.40	685	3.15	42000	55000	PW707D4P150***
* 197.3	7.40	685	2.22	34000	55000	PW607D4P150***
151.0	9.67	889	1.10	25000	35000	PW510D4P150***
149.7	9.75	895	3.59	55000	55000	PW810D4P150***
149.7	9.75	898	2.67	42000	55000	PW710D4P150***
149.7	9.75	898	1.83	34000	50000	PW610D4P150***
* 119.2	12.25	1118	3.68	55000	55000	PW812D4P150***
* 119.2	12.25	1119	2.59	42000	55000	PW712D4P150***
* 119.2	12.25	1120	1.65	34000	50000	PW612D4P150***
* 118.4	12.33	1122	1.06	25000	35000	PW512D4P150***
99.5	14.67	1328	3.10	55000	55000	PW815D4P150***
99.5	14.67	1330	2.21	42000	55000	PW715D4P150***
99.5	14.67	1328	1.47	34000	50000	PW615D4P150***
94.2	15.50	1394	0.97	25000	35000	PW515D4P150***
* 80.0	12.25	1660	2.86	55000	55000	PW812D6P150***
* 80.0	12.25	1658	2.03	42000	55000	PW712D6P150***
* 80.0	12.25	1656	1.30	34000	50000	PW612D6P150***
71.2	20.50	1816	2.19	55000	55000	PW820D4P150***
71.2	20.50	1816	1.64	42000	55000	PW720D4P150***
71.2	20.50	1812	1.14	34000	50000	PW620D4P150***
66.8	14.67	1970	2.43	55000	55000	PW815D6P150***
66.8	14.67	1968	1.74	42000	55000	PW715D6P150***
66.8	14.67	1964	1.16	34000	50000	PW615D6P150***
59.6	24.50	2149	1.94	55000	55000	PW825D4P150***
59.6	24.50	2146	1.37	42000	55000	PW725D4P150***
59.6	24.50	2139	0.92	34000	50000	PW625D4P150***
49.5	29.50	2570	1.55	55000	55000	PW830D4P150***
49.5	29.50	2553	1.05	42000	55000	PW730D4P150***
48.7	30.00	2549	0.92	30300	50000	PW630D4P150***
* 41.7	35.00	2970	1.60	55000	55000	PW835D4P150***
* 41.7	35.00	2953	1.16	40400	55000	PW735D4P150***
* 41.7	35.00	2936	0.81	26100	50000	PW635D4P150***
40.0	24.50	3166	1.52	55000	55000	PW825D6P150***
40.0	24.50	3158	1.07	39100	55000	PW725D6P150***
36.5	40.00	3336	1.39	55000	55000	PW840D4P150***
36.5	40.00	3320	1.02	37900	55000	PW740D4P150***
33.2	29.50	3786	1.21	55000	55000	PW830D6P150***
33.2	29.50	3747	0.83	34600	55000	PW730D6P150***
* 32.4	45.00	3682	1.23	55000	55000	PW845D4P150***
* 32.4	45.00	3647	0.86	35400	55000	PW745D4P150***
29.2	50.00	4032	1.08	55000	55000	PW850D4P150***
* 28.0	35.00	4353	1.25	55000	55000	PW835D6P150***
* 28.0	35.00	4318	0.91	29300	55000	PW735D6P150***
24.5	40.00	4882	1.09	55000	55000	PW840D6P150***
24.5	40.00	4847	0.81	23500	55000	PW740D6P150***
24.3	60.00	4733	0.83	55000	55000	PW860D4P150***
* 21.8	45.00	5374	0.97	50500	55000	PW845D6P150***
19.6	50.00	5876	0.84	46500	55000	PW850D6P150***

The overhung load shown above is based on the maximum motor Power being transmitted. For higher overhung loads consult Renold.



IMPORTANT

Units to ATEX approval must be selected with a minimum service factor of 1.25.

Key

- n₂ Output Speed, rpm
- i Overall Ratio
- M₂ Output Torque Nm, Mechanical
- S_F Service Factor, Mechanical

* - This ratio made to order

For details of unit designation code see page 13.

RENOLD PM Series - PW Type - Motorised - Selection Data

P₁ 18.5 kW		4P - D180MD 1470 RPM					6P - D200LD 980 RPM				
n₂	Actual	M₂	S_F	Overhung	Axial	Product Code					
rpm	Ratio	Nm		Load	Load						
	i			(max.) N	(max.) N						
286.8	5.13	585	3.56	42000	55000	PW705D4P185***					
286.8	5.13	585	2.44	34000	50000	PW605D4P185***					
* 198.6	7.40	840	3.45	55000	55000	PW807D4P185***					
* 198.6	7.40	841	2.56	42000	55000	PW707D4P185***					
* 198.6	7.40	841	1.80	34000	50000	PW607D4P185***					
150.8	9.75	1101	2.91	55000	55000	PW810D4P185***					
150.8	9.75	1103	2.17	42000	55000	PW710D4P185***					
150.8	9.75	1103	1.48	34000	50000	PW610D4P185***					
* 120.0	12.25	1374	2.99	55000	55000	PW812D4P185***					
* 120.0	12.25	1375	2.10	42000	55000	PW712D4P185***					
* 120.0	12.25	1375	1.34	34000	50000	PW612D4P185***					
100.2	14.67	1634	2.51	55000	55000	PW815D4P185***					
100.2	14.67	1634	1.79	42000	55000	PW715D4P185***					
100.2	14.67	1630	1.19	34000	50000	PW615D4P185***					
* 80.0	12.25	2051	2.32	55000	55000	PW812D6P185***					
* 80.0	12.25	2049	1.64	42000	55000	PW712D6P185***					
71.7	20.50	2232	1.78	55000	55000	PW820D4P185***					
71.7	20.50	2232	1.33	42000	55000	PW720D4P185***					
71.7	20.50	2225	0.92	33300	50000	PW620D4P185***					
66.8	14.67	2435	1.97	55000	55000	PW815D6P185***					
66.8	14.67	2432	1.41	42000	55000	PW715D6P185***					
60.0	24.50	2641	1.57	55000	55000	PW825D4P185***					
60.0	24.50	2635	1.11	42000	55000	PW725D4P185***					
49.8	29.50	3159	1.25	55000	55000	PW830D4P185***					
49.8	29.50	3134	0.86	39200	55000	PW730D4P185***					
* 42.0	35.00	3651	1.30	55000	55000	PW835D4P185***					
* 42.0	35.00	3626	0.94	35600	55000	PW735D4P185***					
40.0	24.50	3913	1.23	55000	55000	PW825D6P185***					
40.0	24.50	3900	0.87	33200	55000	PW725D6P185***					
36.8	40.00	4100	1.13	55000	55000	PW840D4P185***					
36.8	40.00	4081	0.83	31700	55000	PW740D4P185***					
33.2	29.50	4680	0.98	55000	55000	PW830D6P185***					
* 32.7	45.00	4527	1.00	53600	55000	PW845D4P185***					
29.4	50.00	4957	0.87	55000	55000	PW850D4P185***					
* 28.0	35.00	5382	1.01	50500	55000	PW835D6P185***					
24.5	40.00	6035	0.88	45200	55000	PW840D6P185***					
* 21.8	45.00	6644	0.78	39500	55000	PW845D6P185***					

The overhung load shown above is based on the maximum motor Power being transmitted. For higher overhung loads consult Renold.



IMPORTANT

Units to ATEX approval must be selected with a minimum service factor of 1.25.

Key

- n₂ Output Speed, rpm
- i Overall Ratio
- M₂ Output Torque Nm, Mechanical
- S_F Service Factor, Mechanical

* - This ratio made to order

For details of unit designation code see page 13.

RENOLD PM Series - PW Type - Motorised - Selection Data

P₁ 22.0 kW						
4P - D180LD 1465 RPM						
6P - D200LXD 975 RPM						
n ₂	Actual	M ₂	S _F	Overhung	Axial	Product Code
rpm	Ratio	Nm		Load	Load	
	i			(max.) N	(max.) N	
285.9	5.13	699	2.98	42000	55000	PW705D4P220***
285.9	5.13	699	2.05	34000	50000	PW605D4P220***
* 198.0	7.40	1004	2.89	55000	55000	PW807D4P220***
* 198.0	7.40	1006	2.14	42000	55000	PW707D4P220***
* 198.0	7.40	1006	1.51	34000	50000	PW607D4P220***
150.3	9.75	1317	2.43	55000	55000	PW810D4P220***
150.3	9.75	1318	1.81	42000	55000	PW710D4P220***
150.3	9.75	1317	1.24	34000	50000	PW610D4P220***
* 119.6	12.25	1642	2.50	55000	55000	PW812D4P220***
* 119.6	12.25	1644	1.76	42000	55000	PW712D4P220***
* 119.6	12.25	1642	1.12	34000	50000	PW612D4P220***
99.9	14.67	1954	2.10	55000	55000	PW815D4P220***
99.9	14.67	1954	1.50	42000	55000	PW715D4P220***
99.9	14.67	1950	1.00	34000	50000	PW615D4P220***
* 79.6	12.25	2455	1.94	55000	55000	PW812D6P220***
* 79.6	12.25	2452	1.37	42000	55000	PW712D6P220***
71.5	20.50	2669	1.49	55000	55000	PW820D4P220***
71.5	20.50	2666	1.12	42000	55000	PW720D4P220***
66.5	14.67	2917	1.65	55000	55000	PW815D6P220***
66.5	14.67	2911	1.18	40700	55000	PW715D6P220***
59.8	24.50	3159	1.32	55000	55000	PW825D4P220***
59.8	24.50	3151	0.93	39100	55000	PW725D4P220***
49.7	29.50	3778	1.05	55000	55000	PW830D4P220***
47.6	20.50	3971	1.18	55000	55000	PW820D6P220***
47.6	20.50	3958	0.87	32800	55000	PW720D6P220***
* 41.9	35.00	4362	1.09	55000	55000	PW835D4P220***
* 41.9	35.00	4336	0.79	29200	55000	PW735D4P220***
39.8	24.50	4688	1.03	55000	55000	PW825D6P220***
36.6	40.00	4904	0.94	54000	55000	PW840D4P220***
33.1	29.50	5600	0.82	48900	55000	PW830D6P220***
* 32.6	45.00	5414	0.84	50300	55000	PW845D4P220***
* 27.9	35.00	6440	0.85	41500	55000	PW835D6P220***

The overhung load shown above is based on the maximum motor Power being transmitted. For higher overhung loads consult Renold.

P₁ 30.0 kW						
4P - D200LD 1480 RPM						
6P - D225MD 985 RPM						
n ₂	Actual	M ₂	S _F	Overhung	Axial	Product Code
rpm	Ratio	Nm		Load	Load	
	i			(max.) N	(max.) N	
288.8	5.13	945	2.95	50300	55000	PW805D4P300***
288.8	5.13	946	2.20	42000	55000	PW705D4P300***
* 200.0	7.40	1361	2.12	55000	55000	PW807D4P300***
* 200.0	7.40	1362	1.58	42000	55000	PW707D4P300***
192.2	5.13	1418	2.37	55000	55000	PW805D6P300***
192.2	5.13	1418	1.78	42000	55000	PW705D6P300***
151.8	9.75	1785	1.79	55000	55000	PW810D4P300***
151.8	9.75	1785	1.33	42000	55000	PW710D4P300***
* 133.1	7.40	2038	1.71	55000	55000	PW807D6P300***
* 133.1	7.40	2036	1.27	42000	55000	PW707D6P300***
* 120.8	12.25	2227	1.84	55000	55000	PW812D4P300***
* 120.8	12.25	2224	1.29	42000	55000	PW712D4P300***
101.0	9.75	2668	1.39	55000	55000	PW810D6P300***
101.0	9.75	2666	1.04	42000	55000	PW710D6P300***
100.9	14.67	2646	1.55	55000	55000	PW815D4P300***
100.9	14.67	2643	1.11	42000	55000	PW715D4P300***
* 80.4	12.25	3324	1.43	55000	55000	PW812D6P300***
* 80.4	12.25	3317	1.01	37900	55000	PW712D6P300***
72.2	20.50	3619	1.10	55000	55000	PW820D4P300***
72.2	20.50	3611	0.82	35700	55000	PW720D4P300***
67.2	14.67	3946	1.21	55000	55000	PW815D6P300***
67.2	14.67	3933	0.87	33000	55000	PW715D6P300***
60.4	24.50	4278	0.97	55000	55000	PW825D4P300***
48.0	20.50	5372	0.87	50600	55000	PW820D6P300***
* 42.3	35.00	5914	0.80	46200	55000	PW835D4P300***

Key

- n₂ Output Speed, rpm
- i Overall Ratio
- M₂ Output Torque Nm, Mechanical
- S_F Service Factor, Mechanical

* - This ratio made to order

For details of unit designation code see page 13.



Units to ATEX approval must be selected with a minimum service factor of 1.25.

RENOLD PM Series - PW Type - Motorised - Selection Data

P_1 37.0 kW		4P - D225SD 1485 RPM				
n_2	Actual Ratio	M_2	S_F	Overhung Load	Axial Load	Product Code
rpm	i	Nm		(max.) N	(max.) N	
289.8	5.13	1165	2.39	49300	55000	PW805D4P370***
289.8	5.13	1166	1.78	42000	55000	PW705D4P370***
* 200.7	7.40	1676	1.72	55000	55000	PW807D4P370***
* 200.7	7.40	1676	1.28	42000	55000	PW707D4P370***
152.3	9.75	2197	1.45	55000	55000	PW810D4P370***
152.3	9.75	2197	1.08	42000	55000	PW710D4P370***
* 121.2	12.25	2740	1.49	55000	55000	PW812D4P370***
* 121.2	12.25	2737	1.05	42000	55000	PW712D4P370***
101.3	14.67	3259	1.26	55000	55000	PW815D4P370***
101.3	14.67	3252	0.90	38300	55000	PW715D4P370***
72.4	20.50	4453	0.89	55000	55000	PW820D4P370***
60.6	24.50	5264	0.78	51400	55000	PW825D4P370***

Key

- n_2 Output Speed, rpm
- i Overall Ratio
- M_2 Output Torque Nm, Mechanical
- S_F Service Factor, Mechanical

* - This ratio made to order

For details of unit designation code see page 13.

The overhung load shown above is based on the maximum motor Power being transmitted. For higher overhung loads consult Renold.

P_1 45.0 kW		4P - D225MD 1480 RPM				
n_2	Actual Ratio	M_2	S_F	Overhung Load	Axial Load	Product Code
rpm	i	Nm		(max.) N	(max.) N	
288.8	5.13	1423	1.96	47600	55000	PW805D4P450***
288.8	5.13	1424	1.46	42000	55000	PW705D4P450***
* 200.0	7.40	2048	1.41	53800	55000	PW807D4P450***
* 200.0	7.40	2048	1.05	42000	55000	PW707D4P450***
151.8	9.75	2687	1.19	55000	55000	PW810D4P450***
151.8	9.75	2684	0.89	42000	55000	PW710D4P450***
* 120.8	12.25	3350	1.22	55000	55000	PW812D4P450***
* 120.8	12.25	3343	0.86	33770	55000	PW712D4P450***
100.9	14.67	3982	1.03	55000	55000	PW815D4P450***



Units to ATEX approval must be selected with a minimum service factor of 1.25.

RENOLD PM Series - PW Type - Motorised Unit - Dimensions

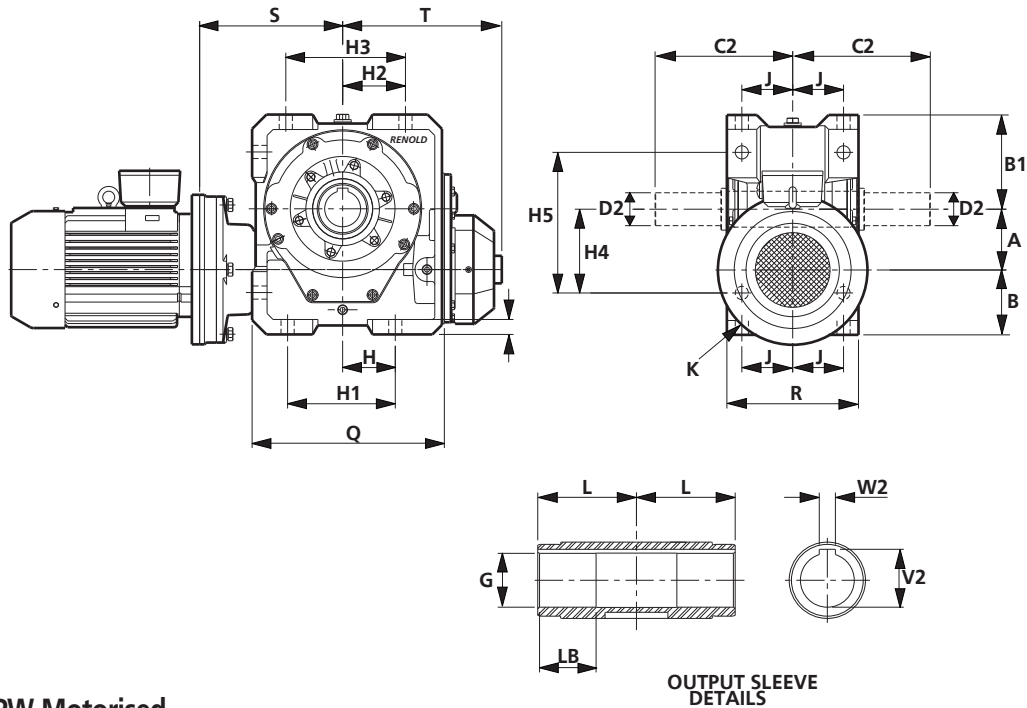

PM Series - PW Motorised

UNIT REF	A (inch)	A (mm)	B	B1	H	H1	H2	H3	H4	H5
PW35	3.5	88.9	91.1	140.0	60	135	85	160	120	205
PW40	4.0	101.6	108.4	157.5	88	180	105	200	140	235
PW50	5.0	127	113.0	195.0	88	180	125	230	160	280
PW60	6.0	152.4	127.6	225.0	120	235	145	270	190	340
PW70	7.0	177.8	157.2	255.5	140	290	160	310	240	412
PW80	8.0	203.2	166.8	280.0	140	310	170	340	256	460

UNIT REF	J	K	Q	R	T	U
PW35	75	17.0	274	186	240	25
PW40	85	21.5	321	220	266	25
PW50	100	21.5	365	250	286	30
PW60	125	25.5	418	305	339	35
PW70	150	25.5	458	360	354	35
PW80	150	25.5	503	360	378	35

UNIT REF	S								
	D80D	D90D	D100D	D112D	D132D	D160D	D180D	D200D	D225D
PW35	250	250	260	260	280	-	-	-	-
PW40	285	285	295	295	315	-	-	-	-
PW50	-	315	325	325	345	375	-	-	-
PW60	-	-	345	345	365	395	395	-	-
PW70	-	-	-	-	405	435	435	435	465
PW80	-	-	-	-	430	460	460	460	490

Output Sleeve

UNIT REF	G	L	LB	V2	W2
PW35	50F7	103	55	53.8	14Js9
PW40	60F7	110	65	64.4	18Js9
PW50	70F7	130	70	74.9	20Js9
PW60	90F7	155	90	95.4	25Js9
PW70	100F7	174	115	106.4	28Js9
PW80	100F7	174	115	106.4	28Js9

Plug-in Output Shaft

UNIT REF	C2	D2
PW35	220	45k6
PW40	230	55m6
PW50	280	65m6
PW60	305	75m6
PW70	355	85m6
PW80	355	95m6

RENOLD PM Series - PW Type - Motorised Unit - Dimensions

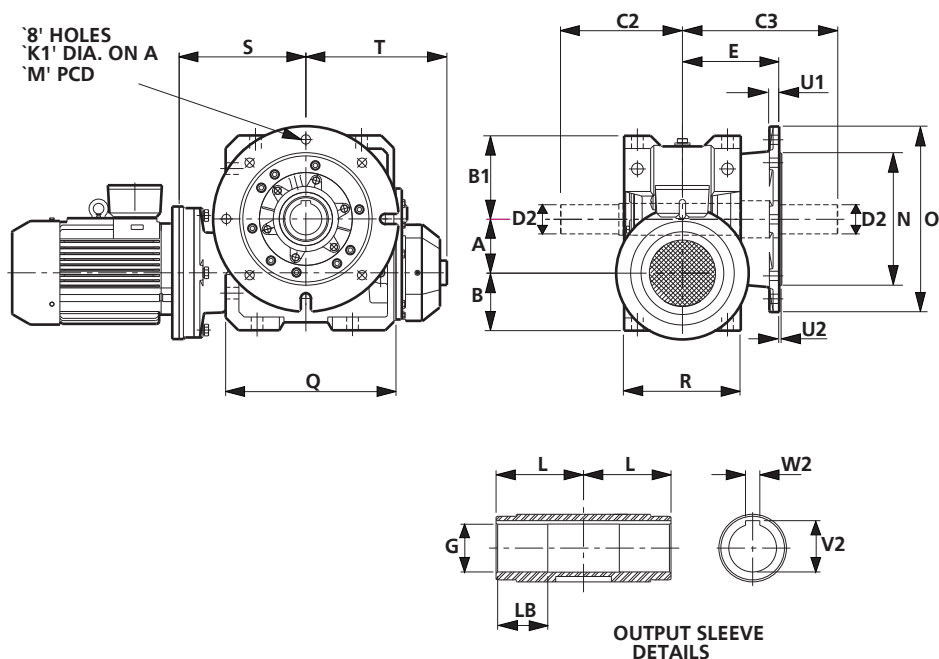

PM Series - PW Motorised - (Horizontal Flange Mounted)

UNIT REF	A (inch)	A (mm)	B	B1	E	K1
PW35	3.5	88.9	91.1	140.0	154	13.5
PW40	4.0	101.6	108.4	157.5	183	17.5
PW50	5.0	127.0	113.0	195.0	197	17.5
PW60	6.0	152.4	127.6	225.0	215	17.5
PW70	7.0	177.8	157.2	255.5	248	17.5
PW80	8.0	203.2	166.8	280.0	248	17.5

UNIT REF	M	N	O	Q	R	T	U1	U2
PW35	265	230h8	300	274	186	240	13	4
PW40	300	250h8	350	321	220	266	19	5
PW50	350	300h8	400	365	250	286	19	5
PW60	400	350h8	450	418	305	339	19	5
PW70	500	450h8	550	458	360	354	24	5
PW80	500	450h8	550	503	360	378	24	5

UNIT REF	S								
	D80D	D90D	D100D	D112D	D132D	D160D	D180D	D200D	D225D
PW35	250	250	260	260	280	-	-	-	-
PW40	285	285	295	295	315	-	-	-	-
PW50	-	315	325	325	345	375	-	-	-
PW60	-	-	345	345	365	395	395	-	-
PW70	-	-	-	-	405	435	435	435	465
PW80	-	-	-	-	430	460	460	460	490

Output Sleeve

UNIT REF	G	L	LB	V2	W2
PW35	50F7	103	55	53.8	14Js9
PW40	60F7	110	65	64.4	18Js9
PW50	70F7	130	70	74.9	20Js9
PW60	90F7	155	90	95.4	25Js9
PW70	100F7	174	115	106.4	28Js9
PW80	100F7	174	115	106.4	28Js9

Plug-in Output Shaft

UNIT REF	C2	C3	D2
PW35	220	264	45k6
PW40	230	293	55m6
PW50	280	337	65m6
PW60	305	355	75m6
PW70	355	418	85m6
PW80	355	418	95m6

RENOLD PM Series - PW Type - Motorised Unit - Dimensions

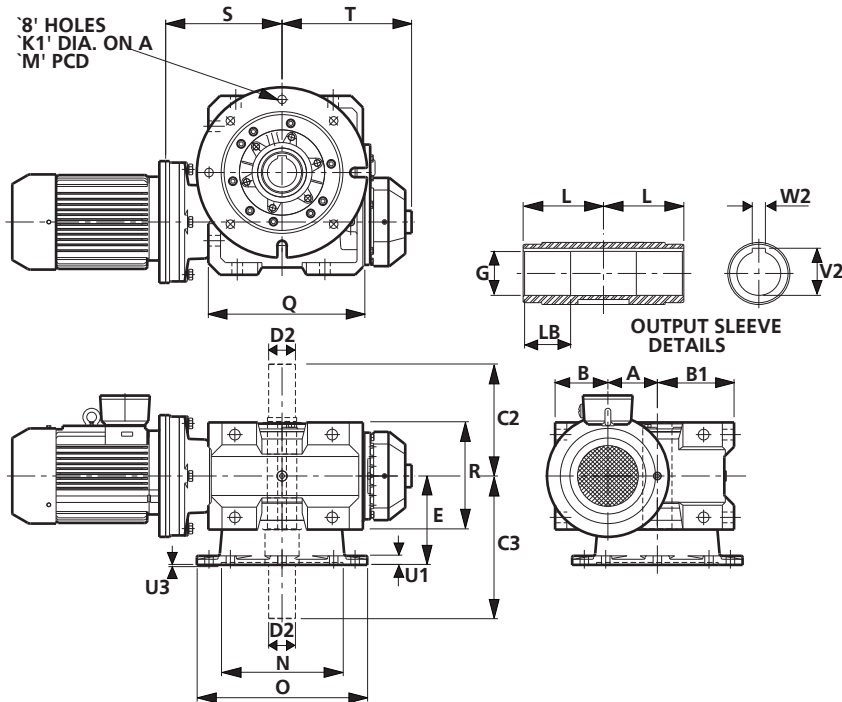

PM Series - PW Motorised - (Vertical Skirt)

UNIT REF	A (inch)	A (mm)	B	B1	E	K1
PW35	3.5	88.9	91.1	140.0	154	13.5
PW40	4.0	101.6	108.4	157.5	183	17.5
PW50	5.0	127.0	113.0	195.0	197	17.5
PW60	6.0	152.4	127.6	225.0	215	17.5
PW70	7.0	177.8	157.2	255.5	248	17.5
PW80	8.0	203.2	166.8	280.0	248	17.5

UNIT REF	M	N	O	Q	R	T	U1	U3
PW35	265	230H8	300	274	186	240	13	5
PW40	300	250H8	350	321	220	266	19	6
PW50	350	300H8	400	365	250	286	19	6
PW60	400	350H8	450	418	305	339	19	6
PW70	500	450H8	550	458	360	354	24	6
PW80	500	450H8	550	503	360	378	24	6

UNIT REF	S								
	D80D	D90D	D100D	D112D	D132D	D160D	D180D	D200D	D225D
PW35	250	250	260	260	280	-	-	-	-
PW40	285	285	295	295	315	-	-	-	-
PW50	-	315	325	325	345	375	-	-	-
PW60	-	-	345	345	365	395	395	-	-
PW70	-	-	-	-	405	435	435	435	465
PW80	-	-	-	-	430	460	460	460	490

Output Sleeve

UNIT REF	G	L	LB	V2	W2
PW35	50F7	103	55	53.8	14Js9
PW40	60F7	110	65	64.4	18Js9
PW50	70F7	130	70	74.9	20Js9
PW60	90F7	155	90	95.4	25Js9
PW70	100F7	174	115	106.4	28Js9
PW80	100F7	174	115	106.4	28Js9

Plug-in Output Shaft

UNIT REF	C2	C3	D2
PW35	220	264	45k6
PW40	230	293	55m6
PW50	280	337	65m6
PW60	305	355	75m6
PW70	355	418	85m6
PW80	355	418	95m6

RENOLD PM Series - PW Type - Output Shaft Dimensions

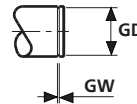
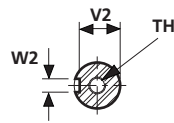
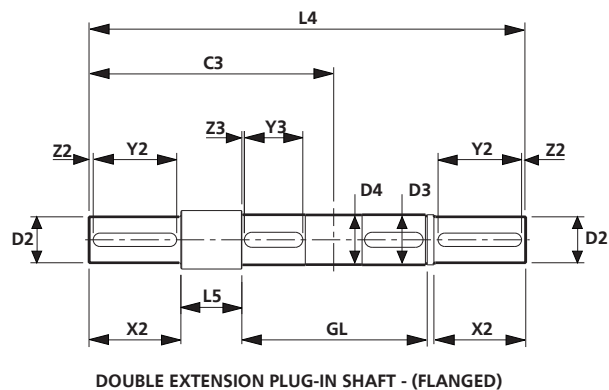
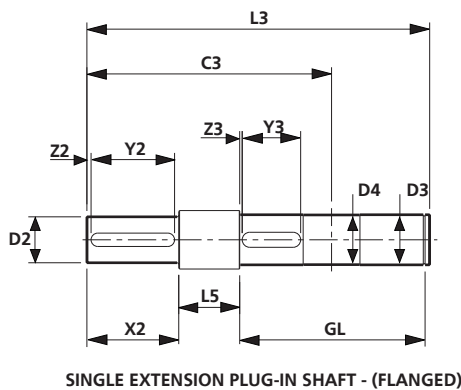
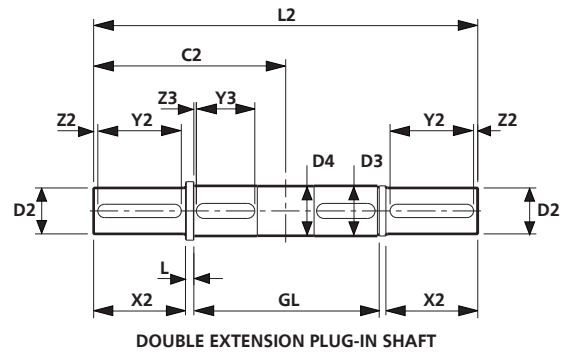
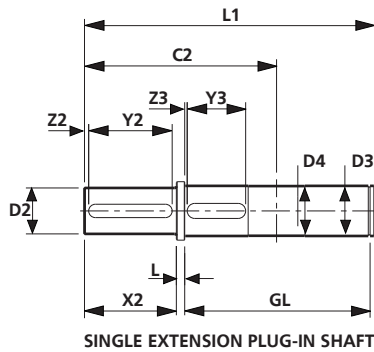

EXTENSION KEYWAY DETAILS CIRCLIP GROOVE DETAILS

Plug-in Shafts

UNIT REF	C2	C3	L	L1	L2	L3	L4	L5	GD	GL	GW
PW35	220	264	7	330.5	440	374.5	484	51	47.00	207.90	2.29
									46.75	207.85	2.15
PW40	230	293	10	347.5	460	410.5	523	73	57.00	222.15	2.29
									56.70	222.10	2.15
PW50	280	337	10	418.5	560	475.5	617	67	67.00	262.65	2.79
									66.70	262.60	2.65
PW60	305	355	10	469.5	610	519.5	660	60	86.50	313.15	3.33
									86.15	313.10	3.15
PW70	355	418	11	538.5	710	601.5	773	74	96.50	351.15	3.33
									96.15	351.10	3.15
PW80	355	418	11	538.5	710	601.5	773	74	96.50	351.15	3.33
									96.15	351.10	3.15

UNIT REF	D2	V2	W2	X2	Y2	Z2	TH	D3	Y3	Z3	D4
PW35	45k6	39.50	14P9	110	100	5	M16x36	50h6	63	3	46
PW40	55m6	49.00	16P9	110	100	5	M20x42	60h6	70	3	56
PW50	65m6	58.00	18P9	140	125	5	M20x42	70h6	90	2	66
PW60	75m6	67.50	20P9	140	125	5	M20x42	90h6	110	3	86
PW70	85m6	76.00	22P9	170	160	5	M20x42	100h6	125	3	96
PW80	95m6	86.00	25P9	170	160	5	M24x50	100h6	125	3	96

RENOLD PM Series - PW Type - Overhung/Axial Load Capacities

PM Series PW - SINGLE REDUCTION -

Overhung Load Capacities @ 1500 RPM Nominal Input Speed (Newtons)

Ratio	Output Speed	Gear Unit Size					
		PW35	PW40	PW50	PW60	PW70	PW80
5/1	300	9000	16400	19100	27400	42000	35500
7.5/1	200	9000	18000	23200	33700	42000	44400
10/1	150	9000	18000	25000	34000	42000	50500
12.5/1	120	9000	18000	25000	34000	41000	54400
15/1	100	9000	18000	25000	34000	40700	55000
20/1	75	9000	18000	25000	34000	40400	55000
25/1	60	9000	18000	25000	34000	40700	55000
30/1	50	9000	18000	25000	34000	42000	55000
35/1	43	9000	18000	25000	34000	37400	55000
40/1	38	9000	18000	25000	34000	37600	55000
45/1	33	9000	18000	25000	34000	39300	55000
50/1	30	9000	18000	25000	34000	40000	55000
60/1	25	9000	18000	25000	34000	41900	55000
70/1	21	9000	18000	25000	34000	42000	55000

- based on Gear Unit transmitting Mechanical Rating

PM SERIES PW - SINGLE REDUCTION -

Axial Load Capacities (Newtons)

Ratio	Output Speed	Gear Unit Size					
		PW35	PW40	PW50	PW60	PW70	PW80
5/1	300	15200	20000	27300	37000	53500	47900
7.5/1	200	16000	20000	35000	48500	55000	55000
10/1	150	16000	20000	35000	50000	55000	55000
12.5/1	120	16000	20000	35000	50000	55000	55000
15/1	100	16000	20000	35000	50000	55000	55000
20/1	75	16000	20000	35000	50000	55000	55000
25/1	60	16000	20000	35000	50000	55000	55000
30/1	50	16000	20000	35000	50000	55000	55000
35/1	43	16000	20000	35000	50000	55000	55000
40/1	38	16000	20000	35000	50000	55000	55000
45/1	33	16000	20000	35000	50000	55000	55000
50/1	30	16000	20000	35000	50000	55000	55000
60/1	25	16000	20000	35000	50000	55000	55000
70/1	21	16000	20000	35000	50000	55000	55000

The above values can be increased if the unit is not transmitting the full mechanical rating. Consult Renold.

RENOLD PM Series - PW Type - Exact RatioSingle Reduction
PM Series - PW Type

Gear Size	PW35	PW40	PW50	PW60	PW70	PW80
Nominal Ratio	Actual Ratio					
5	5.17	5.17	5.17	5.13	5.13	5.13
**7.5	7.75	7.25	7.25	7.40	7.40	7.40
10	10.33	9.67	9.67	9.75	9.75	9.75
**12.5	12	12.33	12.33	12.25	12.25	12.25
15	15.50	15.50	15.50	14.67	14.67	14.67
20	20	20.50	20.50	20.50	20.50	20.50
25	25	25	24.50	24.50	24.50	24.50
30	30	30	30	30	29.50	29.50
**35	35	35	35	35	35	35
40	40	40	40	40	40	40
**45	45	45	45	45	45	45
50	49	50	50	50	50	50
60	60	60	60	60	60	60
70	70	70	70	70	70	70

Preferred Ratios

The preferred ratios marked ** above have been chosen with a view to providing a competitive leadtime.

Mineral and Synthetic Oils

Nominal ratio: 5/1 Preferred Ratio

Input rpm	Output rpm	Product Code Centre Distance Gear Ratings	PW3REDXXX05***		PW4REDXXX05***		PW5REDXXX05***		PW6REDXXX05***		PW7REDXXX05***		PW8REDXXX05***	
			3.5"		4"		5"		6"		7"		8"	
			Min	Syn	Min	Syn	Min	Syn	Min	Syn	Min	Syn	Min	Syn
1800	360	Input kW, Thermal	16.7	20.0	26.2	31.4	40.6	48.7	59.2	71.0	89.9	108.2	112.1	134.6
		Output Torque Nm, Thermal	432	522	681	823	1056	1277	1531	1852	2333	2822	2911	3520
		Input kW, Mechanical	12.2	13.6	15.5	17.2	27.2	30.2	45.5	50.6	65.7	73.0	87.4	97.2
		Output Torque Nm, Mechanical	316	354	401	449	706	791	1177	1318	1703	1907	2269	2541
		Efficiency %	94.1	95.1	94.3	95.2	94.8	95.6	95.1	95.8	95.3	96.1	95.5	96.2
1500	300	Input kW, Thermal	14.7	17.5	22.9	27.5	35.4	42.4	51.5	61.8	78.5	94.2	98.3	118.0
		Output Torque Nm, Thermal	452	547	711	860	1101	1332	1595	1931	2439	2951	3059	3700
		Input kW, Mechanical	11.1	12.3	14.1	15.6	24.6	27.3	41.0	45.5	59.5	66.1	79.6	88.5
		Output Torque Nm, Mechanical	343	385	436	488	764	856	1267	1419	1846	2067	2475	2772
		Efficiency %	93.8	94.8	94.0	95.0	94.5	95.4	94.8	95.6	95.1	95.9	95.3	96.0
1200	240	Input kW, Thermal	12.2	14.6	19.1	22.8	29.2	35.0	42.4	50.9	64.6	77.5	81.1	97.2
		Output Torque Nm, Thermal	470	568	734	889	1132	1370	1634	1979	2498	3023	3142	3801
		Input kW, Mechanical	10.0	11.1	12.6	14.0	21.9	24.2	36.4	40.4	52.8	58.6	70.9	78.8
		Output Torque Nm, Mechanical	384	430	485	544	846	947	1401	1569	2039	2284	2748	3078
		Efficiency %	93.3	94.4	93.6	94.6	94.1	95.0	94.4	95.3	94.8	95.6	95.0	95.8
1000	200	Input kW, Thermal	10.7	12.8	16.5	19.8	25.2	30.2	36.4	43.7	55.3	66.3	69.4	83.2
		Output Torque Nm, Thermal	489	592	761	921	1166	1412	1677	2031	2557	3095	3216	3892
		Input kW, Mechanical	9.05	10.0	11.5	12.7	20.1	22.2	33.5	37.2	48.2	53.5	64.0	71.0
		Output Torque Nm, Mechanical	415	465	527	591	928	1039	1544	1730	2230	2498	2965	3321
		Efficiency %	92.9	94.0	93.1	94.2	93.7	94.7	94.1	95.0	94.4	95.3	94.7	95.6
750	150	Input kW, Thermal	8.75	10.5	13.5	16.1	20.3	24.3	29.1	34.9	43.8	52.5	54.8	65.7
		Output Torque Nm, Thermal	531	643	820	994	1243	1506	1773	2149	2685	3252	3368	4078
		Input kW, Mechanical	7.60	8.40	9.56	10.6	16.8	18.6	28.3	29.9	41.1	45.6	55.3	61.4
		Output Torque Nm, Mechanical	461	516	582	651	1027	1151	1723	1844	2519	2821	3400	3808
		Efficiency %	92.1	93.4	92.4	93.6	93.0	94.1	93.4	94.5	93.9	94.8	94.2	95.1
500	100	Input kW, Thermal	6.89	8.22	10.5	12.5	15.6	18.6	22.0	26.3	32.7	39.2	40.6	48.6
		Output Torque Nm, Thermal	619	750	947	1149	1413	1713	1990	2414	2976	3608	3703	4488
		Input kW, Mechanical	6.01	6.62	7.62	8.41	13.4	14.8	20.0	20.0	32.4	35.9	43.5	48.1
		Output Torque Nm, Mechanical	539	604	687	770	1216	1362	1811	1830	2947	3300	3965	4441
		Efficiency %	91.0	92.5	91.4	92.8	92.0	93.3	92.4	93.6	92.9	94.0	93.2	94.3
250	50	Input kW, Thermal	5.02	5.98	7.54	8.99	10.9	13.0	15.1	18.0	21.9	26.2	26.8	32.0
		Output Torque Nm, Thermal	883	1072	1333	1619	1938	2354	2672	3248	3911	4751	4794	5821
		Input kW, Mechanical	3.85	4.23	4.62	4.60	7.89	7.86	10.1	10.0	18.3	18.3	28.0	28.2
		Output Torque Nm, Mechanical	677	758	816	827	1402	1421	1781	1804	3266	3306	5010	5115
		Efficiency %	89.1	90.8	89.5	91.1	90.1	91.6	90.4	91.9	91.0	92.4	91.4	92.8

For details of unit designation code see page 13.



Units to ATEX approval must be selected with a minimum service factor of 1.25.

RENOLD PM Series - PW Type - Speed Reducer - Selection Data

Mineral and Synthetic Oils

Nominal ratio: 7.5/1 (THIS RATIO MADE TO ORDER ONLY)

Input rpm	Output rpm	Product Code Centre Distance Gear Ratings	PW3REDXXX07***		PW4REDXXX07***		PW5REDXXX07***		PW6REDXXX07***		PW7REDXXX07***		PW8REDXXX07***	
			3.5"		4"		5"		6"		7"		8"	
			Min	Syn	Min	Syn	Min	Syn	Min	Syn	Min	Syn	Min	Syn
1800	240	Input kW, Thermal	13.7	16.3	23.3	27.9	36.4	43.5	54.0	64.6	82.1	98.5	103.4	123.8
		Output Torque Nm, Thermal	523	631	842	1018	1319	1594	2009	2428	3064	3702	3858	466
		Input kW, Mechanical	9.8	10.9	11.4	12.6	19.0	21.1	33.4	37.1	47.7	52.9	63.6	70.7
		Output Torque Nm, Mechanical	374	419	409	458	689	772	1238	1387	1774	1987	2372	2657
		Efficiency %	92.8	94.0	93.5	94.5	94.0	95.0	94.5	95.3	94.8	95.6	95.0	95.8
1500	200	Input kW, Thermal	12.0	14.3	20.4	24.4	31.6	37.8	46.9	56.1	71.2	85.3	89.7	107.0
		Output Torque Nm, Thermal	547	661	879	1063	1372	1658	2084	2519	3178	3840	4013	4848
		Input kW, Mechanical	9.03	10.0	10.5	11.6	17.4	19.3	30.2	33.5	42.9	47.6	57.5	63.9
		Output Torque Nm, Mechanical	411	461	450	504	752	842	1340	1501	1908	2137	2568	2877
		Efficiency %	92.4	93.6	93.2	94.2	93.7	94.7	94.2	95.1	94.5	95.4	94.7	95.6
1200	160	Input kW, Thermal	10.0	11.9	16.9	20.2	26.1	31.2	38.5	46.0	58.3	69.7	73.4	87.9
		Output Torque Nm, Thermal	568	687	908	1098	1407	1702	2128	2573	3235	3911	4087	4939
		Input kW, Mechanical	7.88	8.70	9.19	10.2	15.5	17.2	27.1	30.1	38.6	42.9	51.5	57.2
		Output Torque Nm, Mechanical	446	500	491	550	833	933	1497	1677	2142	2399	2863	3207
		Efficiency %	91.8	93.1	92.7	93.8	93.2	94.3	93.8	94.7	94.1	95.1	94.4	95.3
1000	133.3	Input kW, Thermal	8.76	10.4	14.7	17.6	22.5	26.9	33.0	39.5	49.8	59.6	62.6	74.9
		Output Torque Nm, Thermal	592	716	942	1140	1450	1754	2182	2639	3304	3994	4166	5036
		Input kW, Mechanical	7.09	7.82	8.20	9.07	13.8	15.3	24.1	26.7	34.7	38.4	46.6	51.6
		Output Torque Nm, Mechanical	479	536	524	587	888	995	1593	1784	2297	2572	3095	3466
		Efficiency %	91.3	92.7	92.2	93.4	92.8	94.0	93.4	94.4	93.8	94.8	94.1	95.0
750	100	Input kW, Thermal	7.22	8.58	12.0	14.4	18.2	21.7	26.4	31.6	39.5	47.2	49.4	59.1
		Output Torque Nm, Thermal	644	779	1019	1233	1549	1874	2310	2795	3468	4195	4353	5264
		Input kW, Mechanical	6.05	6.66	7.01	7.73	11.7	13.0	20.5	22.7	29.1	32.2	38.8	43.0
		Output Torque Nm, Mechanical	539	604	592	663	997	1116	1789	2004	2555	2862	3415	3825
		Efficiency %	90.4	91.9	91.5	92.8	92.1	93.4	92.7	93.8	93.1	94.2	93.4	94.5
500	66.7	Input kW, Thermal	5.72	6.79	9.44	11.3	14.0	16.7	20.1	24.0	29.6	35.4	36.7	43.8
		Output Torque Nm, Thermal	755	913	1184	1434	1768	2141	2603	3152	3856	4668	4796	5804
		Input kW, Mechanical	4.67	5.13	5.43	5.98	9.17	10.1	16.0	17.7	22.7	25.1	30.3	33.5
		Output Torque Nm, Mechanical	616	690	679	761	1155	1294	2071	2319	2957	3312	3956	4431
		Efficiency %	89.2	90.8	90.3	91.9	91.0	92.4	91.6	92.9	92.1	93.3	92.4	93.6
250	33.3	Input kW, Thermal	4.21	4.99	6.87	8.16	9.92	11.8	13.9	16.6	20.1	23.9	24.5	29.2
		Output Torque Nm, Thermal	1086	1315	1684	2042	2450	2970	3535	4287	5124	6212	6270	7598
		Input kW, Mechanical	2.97	3.25	3.44	3.78	5.85	6.42	10.2	10.5	14.7	16.1	19.6	21.6
		Output Torque Nm, Mechanical	764	856	842	944	1441	1614	2598	2705	3735	4184	5027	5630
		Efficiency %	87.0	89.0	88.4	90.2	89.1	90.8	89.7	91.3	90.1	91.7	90.5	92.0

For details of unit designation code see page 13.



Units to ATEX approval must be selected with a minimum service factor of 1.25.

Mineral and Synthetic Oils

Nominal ratio: 10/1 Preferred Ratio

Input rpm	Output rpm	Product Code Centre Distance Gear Ratings	PW3REDXXX10***		PW4REDXXX10***		PW5REDXXX10***		PW6REDXXX10***		PW7REDXXX10***		PW8REDXXX10***	
			3.5"		4"		5"		6"		7"		8"	
			Min	Syn	Min	Syn	Min	Syn	Min	Syn	Min	Syn	Min	Syn
1800	180	Input kW, Thermal	11.3	13.5	20.0	23.9	31.2	37.2	47.9	57.2	72.9	87.3	92.1	110.2
		Output Torque Nm, Thermal	566	683	953	1151	1494	1804	2329	2813	3563	4303	4511	5447
		Input kW, Mechanical	8.28	9.14	10.0	11.1	16.6	18.4	27.3	30.3	39.3	43.6	52.6	58.4
		Output Torque Nm, Mechanical	415	464	475	532	793	889	1323	1482	1913	2143	2568	2876
		Efficiency %	91.4	92.7	92.5	93.7	93.1	94.1	93.7	94.7	94.1	95.0	94.3	95.2
1500	150	Input kW, Thermal	9.91	11.8	17.5	20.8	27.1	32.4	41.5	49.6	63.1	75.4	79.8	95.4
		Output Torque Nm, Thermal	593	716	994	1200	1552	1874	2410	2912	3682	4447	4668	5638
		Input kW, Mechanical	7.41	8.18	9.00	9.94	15.1	16.8	25.0	27.7	36.3	40.2	48.5	53.8
		Output Torque Nm, Mechanical	443	496	510	571	864	967	1450	1624	2113	2366	2832	3172
		Efficiency %	90.8	92.2	92.1	93.3	92.7	93.8	93.4	94.4	93.8	94.8	94.1	95.0
1200	120	Input kW, Thermal	8.30	9.85	14.6	17.3	22.4	26.7	34.0	40.6	51.5	61.6	65.1	77.8
		Output Torque Nm, Thermal	616	743	1027	1241	1592	1923	2458	2971	3739	4517	4736	5721
		Input kW, Mechanical	6.51	7.17	7.87	8.69	13.1	14.5	21.7	24.0	31.8	35.2	42.6	47.2
		Output Torque Nm, Mechanical	482	540	554	620	927	1039	1564	1752	2300	2576	3098	3470
		Efficiency %	90.1	91.6	91.5	92.8	92.1	93.4	92.9	94.0	93.3	94.4	93.7	94.7
1000	100	Input kW, Thermal	7.26	8.61	12.7	15.1	19.3	23.0	29.2	34.9	44.0	52.6	55.4	66.2
		Output Torque Nm, Thermal	642	775	1067	1289	1641	1982	2521	3047	3815	4610	4821	5825
		Input kW, Mechanical	5.88	6.46	7.10	7.83	11.9	13.1	19.5	21.6	28.3	31.3	37.8	41.9
		Output Torque Nm, Mechanical	519	581	596	668	1004	1125	1681	1882	2448	2741	3285	3680
		Efficiency %	89.5	91.1	91.0	92.4	91.7	93.0	92.5	93.6	92.9	94.0	93.3	94.3
750	75	Input kW, Thermal	6.00	7.10	10.4	12.4	15.7	18.6	23.4	27.9	35.0	41.7	43.8	52.2
		Output Torque Nm, Thermal	699	844	1155	1397	1754	2121	2672	3231	4007	4844	5035	6085
		Input kW, Mechanical	4.96	5.44	5.99	6.60	10.0	11.0	16.4	18.2	24.0	26.6	32.2	35.6
		Output Torque Nm, Mechanical	577	646	665	745	1116	1250	1871	2096	2752	3083	3702	4146
		Efficiency %	88.5	90.3	90.1	91.7	90.8	92.3	91.7	93.0	92.2	93.4	92.6	93.7
500	50	Input kW, Thermal	4.77	5.64	8.19	9.72	12.1	14.4	17.9	21.3	26.3	31.4	32.6	38.9
		Output Torque Nm, Thermal	820	991	1347	1629	2009	2429	3022	3656	4469	5405	5559	6723
		Input kW, Mechanical	3.77	4.13	4.56	5.01	7.74	8.51	12.8	14.1	18.7	20.6	25.0	27.6
		Output Torque Nm, Mechanical	648	726	748	837	1280	1433	2158	2417	3171	3551	4260	4772
		Efficiency %	87.0	89.0	88.9	90.6	89.6	91.2	90.6	92.0	91.1	92.5	91.5	92.8
250	25	Input kW, Thermal	3.55	4.18	6.00	7.10	8.65	10.2	12.5	14.9	18.0	21.4	21.9	26.1
		Output Torque Nm, Thermal	1184	1432	1926	2333	2798	3387	4134	5007	5981	7243	7316	8856
		Input kW, Mechanical	2.41	2.63	2.90	3.18	4.93	5.40	8.14	8.26	11.9	13.1	15.9	17.5
		Output Torque Nm, Mechanical	804	901	929	1040	1591	1782	2682	2775	3942	4415	5297	5933
		Efficiency %	84.5	86.8	86.7	88.7	87.4	89.4	88.5	90.3	89.0	90.7	89.4	91.1

For details of unit designation code see page 13.



IMPORTANT Units to ATEX approval must be selected with a minimum service factor of 1.25.

Mineral and Synthetic Oils

Nominal ratio: 15/1 Preferred Ratio

Input rpm	Output rpm	Product Code Centre Distance Gear Ratings	PW3REDXXX15***		PW4REDXXX15***		PW5REDXXX15***		PW6REDXXX15***		PW7REDXXX15***		PW8REDXXX15***	
			3.5"		4"		5"		6"		7"		8"	
			Min	Syn	Min	Syn	Min	Syn	Min	Syn	Min	Syn	Min	Syn
1800	120	Input kW, Thermal	8.29	9.85	14.2	17.0	23.1	27.4	36.7	43.7	55.9	66.6	70.7	84.2
		Output Torque Nm, Thermal	603	727	1057	1276	1730	2087	2633	3178	4033	4865	5113	6170
		Input kW, Mechanical	5.89	6.46	8.44	9.29	15.0	16.5	22.8	25.2	34.0	37.6	47.2	52.2
		Output Torque Nm, Mechanical	427	478	623	697	1120	1254	1630	1825	2444	2737	3404	3812
		Efficiency %	88.2	90.0	89.7	91.3	90.9	92.3	91.9	93.2	92.4	93.6	92.8	93.9
1500	100	Input kW, Thermal	7.30	8.62	12.5	14.8	20.1	23.8	31.8	37.8	48.3	57.5	61.1	72.8
		Output Torque Nm, Thermal	632	762	1103	1332	1794	2166	2722	3286	4160	5020	5278	6369
		Input kW, Mechanical	5.32	5.83	7.64	8.40	13.4	14.8	20.2	22.3	30.2	33.4	42.2	46.7
		Output Torque Nm, Mechanical	460	515	672	752	1195	1339	1725	1932	2598	2910	3641	4078
		Efficiency %	87.5	89.4	89.1	90.7	90.3	91.8	91.5	92.8	92.0	93.2	92.4	93.6
1200	80	Input kW, Thermal	6.13	7.23	10.5	12.4	16.6	19.7	26.1	31.1	39.5	47.0	49.8	59.3
		Output Torque Nm, Thermal	656	792	1141	1378	1841	2222	2776	3351	4221	5095	5345	6451
		Input kW, Mechanical	4.69	5.14	6.72	7.38	11.9	13.1	17.9	19.7	26.4	29.2	36.4	40.2
		Output Torque Nm, Mechanical	501	562	732	819	1312	1469	1896	2123	2818	3156	3902	4370
		Efficiency %	86.6	88.6	88.3	90.1	89.6	91.2	90.8	92.2	91.4	92.7	91.8	93.1
1000	66.7	Input kW, Thermal	5.38	6.34	9.13	10.8	14.4	17.1	22.5	26.7	33.8	40.2	42.5	50.5
		Output Torque Nm, Thermal	684	826	1186	1432	1899	2293	2847	3438	4307	5199	5438	6564
		Input kW, Mechanical	4.16	4.55	5.96	6.54	10.5	11.6	16.0	17.6	23.9	26.4	33.2	36.6
		Output Torque Nm, Mechanical	529	592	773	866	1386	1552	2024	2267	3043	3408	4245	4755
		Efficiency %	85.8	87.9	87.6	89.5	88.9	90.6	90.3	91.8	90.8	92.3	91.3	92.6
750	50	Input kW, Thermal	4.47	5.25	7.53	8.88	11.7	13.9	18.1	21.5	26.9	32.0	33.6	39.9
		Output Torque Nm, Thermal	746	900	1287	1554	2035	2458	3022	3649	4527	5466	5681	6859
		Input kW, Mechanical	3.53	3.85	5.04	5.51	8.90	9.77	13.4	14.8	20.0	22.0	27.8	30.6
		Output Torque Nm, Mechanical	590	660	860	963	1544	1730	2238	2507	3360	3763	4689	5252
		Efficiency %	84.5	86.8	86.5	88.5	87.9	89.7	89.3	90.9	89.9	91.5	90.4	91.9
500	33.3	Input kW, Thermal	3.58	4.19	5.98	7.03	9.14	10.8	13.9	16.4	20.4	24.1	25.2	29.9
		Output Torque Nm, Thermal	877	1059	1504	1817	2340	2826	3425	4139	5059	6112	6284	7590
		Input kW, Mechanical	2.74	2.98	3.90	4.24	6.89	7.19	10.4	11.5	15.6	17.1	21.6	23.8
		Output Torque Nm, Mechanical	671	752	980	1093	1761	1881	2572	2880	3866	4329	5393	6040
		Efficiency %	82.7	85.2	84.9	87.1	86.3	88.4	87.9	89.7	88.5	90.3	89.0	90.7
250	16.7	Input kW, Thermal	2.69	3.14	4.44	5.20	6.62	7.78	9.84	11.6	14.1	16.7	17.1	20.2
		Output Torque Nm, Thermal	1269	1533	2162	2613	3286	3972	4711	5696	6807	8228	8310	10043
		Input kW, Mechanical	1.71	1.85	2.21	2.16	3.73	3.66	6.51	6.97	9.77	10.7	13.6	14.9
		Output Torque Nm, Mechanical	806	903	1073	1083	1846	1864	3113	3420	4708	5272	6611	7404
		Efficiency %	79.6	82.5	82.1	84.6	83.6	86.0	85.4	87.5	86.0	88.1	86.5	88.5

For details of unit designation code see page 13.



Units to ATEX approval must be selected with a minimum service factor of 1.25.

RENOLD PM Series - PW Type - Speed Reducer - Selection Data

Mineral and Synthetic Oils

Nominal ratio: 20/1 Preferred Ratio

Input rpm	Output rpm	Product Code Centre Distance Gear Ratings	PW3REDXXX20***		PW4REDXXX20***		PW5REDXXX20***		PW6REDXXX20***		PW7REDXXX20***		PW8REDXXX20***	
			3.5"		4"		5"		6"		7"		8"	
			Min	Syn	Min	Syn	Min	Syn	Min	Syn	Min	Syn	Min	Syn
1800	90	Input kW, Thermal	5.95	6.97	11.9	14.0	18.5	21.9	27.5	32.6	41.7	49.5	52.7	62.5
		Output Torque Nm, Thermal	529	638	1139	1374	1790	2160	2675	3226	4098	4942	5186	6255
		Input kW, Mechanical	5.01	5.46	6.15	6.75	10.7	11.8	17.4	19.1	25.4	28.0	34.1	37.6
		Output Torque Nm, Mechanical	445	499	586	656	1035	1159	1687	1890	2487	2785	3350	3752
		Efficiency %	83.8	86.1	87.5	89.4	88.5	90.2	89.3	90.9	89.9	91.4	90.3	91.8
1500	75	Input kW, Thermal	5.25	6.15	10.4	12.3	16.1	19.1	23.8	28.2	36.2	42.9	45.6	54.1
		Output Torque Nm, Thermal	555	669	1188	1434	1858	2241	2767	3337	4230	5102	5357	6461
		Input kW, Mechanical	4.61	5.02	5.56	6.09	9.88	10.8	15.7	17.2	22.6	24.9	30.2	33.2
		Output Torque Nm, Mechanical	486	545	630	705	1132	1268	1814	2031	2636	2953	3536	3960
		Efficiency %	82.8	85.3	86.8	88.8	87.9	89.7	88.7	90.4	89.3	90.9	89.8	91.3
1200	60	Input kW, Thermal	4.43	5.17	8.74	10.3	13.4	15.8	19.6	23.2	29.7	35.1	37.3	44.1
		Output Torque Nm, Thermal	576	694	1230	1485	1906	2300	2821	3404	4294	5180	5428	6547
		Input kW, Mechanical	4.06	4.40	4.83	5.28	8.63	9.46	13.8	15.2	20.1	22.1	26.9	29.6
		Output Torque Nm, Mechanical	527	590	677	758	1225	1372	1981	2218	2907	3256	3907	4375
		Efficiency %	81.6	84.2	85.9	88.0	87.0	88.9	87.8	89.6	88.5	90.3	89.1	90.7
1000	50	Input kW, Thermal	3.90	4.54	7.65	9.00	11.6	13.7	16.9	20.0	25.4	30.0	31.9	37.7
		Output Torque Nm, Thermal	600	723	1280	1545	1967	2373	2894	3491	4381	5286	5523	6663
		Input kW, Mechanical	3.65	3.96	4.35	4.75	7.74	8.46	12.3	13.5	17.9	19.6	24.0	26.4
		Output Torque Nm, Mechanical	562	629	725	812	1306	1463	2105	2357	3071	3440	4157	4655
		Efficiency %	80.5	83.3	85.1	87.3	86.2	88.3	87.1	89.0	87.8	89.7	88.4	90.1
750	37.5	Input kW, Thermal	3.25	3.77	6.33	7.44	9.49	11.2	13.7	16.1	20.3	24.0	25.3	29.9
		Output Torque Nm, Thermal	652	786	1391	1679	2109	2545	3071	3705	4605	5556	5769	6961
		Input kW, Mechanical	3.10	3.34	3.66	3.98	6.51	7.11	10.4	11.3	15.1	16.6	20.2	22.2
		Output Torque Nm, Mechanical	621	696	800	896	1444	1617	2322	2600	3419	3830	4610	5163
		Efficiency %	78.8	81.8	83.9	86.2	85.0	87.2	85.9	88.0	86.6	88.6	87.2	89.1
500	25	Input kW, Thermal	2.61	3.02	5.06	5.92	7.44	8.72	10.6	12.4	15.5	18.2	19.1	22.4
		Output Torque Nm, Thermal	762	920	1630	1968	2426	2929	3479	4200	5144	6209	6380	7699
		Input kW, Mechanical	2.40	2.58	2.80	3.04	4.99	5.43	8.03	8.75	11.7	12.8	15.6	17.0
		Output Torque Nm, Mechanical	700	784	899	1006	1624	1819	2643	2960	3882	4347	5214	5840
		Efficiency %	76.4	79.6	82.0	84.6	83.1	85.6	84.0	86.4	84.8	87.1	85.5	87.6
250	12.5	Input kW, Thermal	1.98	2.28	3.79	4.42	5.43	6.34	7.54	8.80	10.8	12.6	13.1	15.3
		Output Torque Nm, Thermal	1095	1321	2355	2845	3412	4121	4782	5775	6915	8350	8431	10180
		Input kW, Mechanical	1.53	1.63	1.63	1.58	3.13	3.31	5.05	5.48	7.39	8.02	9.90	10.7
		Output Torque Nm, Mechanical	845	946	1006	1015	1959	2148	3202	3586	4724	5291	6376	7141
		Efficiency %	72.3	75.9	79.0	81.9	80.0	82.9	80.9	83.6	81.7	84.3	82.3	84.8

For details of unit designation code see page 13.



IMPORTANT

Units to ATEX approval must be selected with a minimum service factor of 1.25.

RENOLD PM Series - PW Type - Speed Reducer - Selection Data

Mineral and Synthetic Oils

Nominal ratio: 25/1 Preferred Ratio

Input rpm	Output rpm	Product Code Centre Distance Gear Ratings	PW3REDXXX25***		PW4REDXXX25***		PW5REDXXX25***		PW6REDXXX25***		PW7REDXXX25***		PW8REDXXX25***	
			3.5"		4"		5"		6"		7"		8"	
			Min	Syn	Min	Syn	Min	Syn	Min	Syn	Min	Syn	Min	Syn
1800	72	Input kW, Thermal	5.43	6.35	9.15	10.7	16.6	19.5	24.6	29.0	37.3	44.2	47.1	55.9
		Output Torque Nm, Thermal	594	716	1024	1235	1883	2271	2818	3398	4316	5206	5481	6610
		Input kW, Mechanical	4.52	4.91	6.32	6.89	8.87	9.73	14.1	15.4	20.8	22.8	29.5	32.5
		Output Torque Nm, Mechanical	493	552	705	790	1004	1125	1608	1800	2393	2680	3421	3832
		Efficiency %	82.2	84.7	84.1	86.4	87.1	89.0	87.9	89.7	88.6	90.3	89.1	90.8
1500	60	Input kW, Thermal	4.80	5.61	8.05	9.43	14.4	17.0	21.3	25.2	32.3	38.2	40.8	48.2
		Output Torque Nm, Thermal	622	750	1069	1289	1953	2356	2912	3512	4450	5367	5651	6815
		Input kW, Mechanical	4.08	4.42	5.70	6.20	8.00	8.76	12.8	14.0	18.9	20.8	26.6	29.2
		Output Torque Nm, Mechanical	527	590	755	845	1078	1207	1743	1952	2600	2912	3668	4108
		Efficiency %	81.2	83.8	83.2	85.6	86.4	88.3	87.2	89.1	88.0	89.8	88.6	90.3
1200	48	Input kW, Thermal	4.06	4.73	6.75	7.90	12.0	14.1	17.6	20.7	26.5	31.3	33.3	39.4
		Output Torque Nm, Thermal	646	779	1105	1333	2004	2418	2969	3581	4513	5444	5719	6898
		Input kW, Mechanical	3.58	3.88	4.99	5.42	6.99	7.63	11.1	12.1	16.6	18.2	23.4	25.7
		Output Torque Nm, Mechanical	569	638	815	913	1163	1303	1867	2091	2814	3151	4010	4491
		Efficiency %	79.9	82.7	82.0	84.6	85.4	87.5	86.3	88.3	87.1	89.0	87.8	89.6
1000	40	Input kW, Thermal	3.58	4.16	5.92	6.91	10.4	12.2	15.2	17.9	22.7	26.8	28.5	33.6
		Output Torque Nm, Thermal	673	812	1148	1384	2069	2497	3046	3675	4605	5555	5817	7017
		Input kW, Mechanical	3.22	3.48	4.49	4.86	6.26	6.83	10.00	11.00	14.8	16.2	20.9	22.9
		Output Torque Nm, Mechanical	606	679	868	972	1239	1388	2006	2247	2992	3351	4255	4765
		Efficiency %	78.8	81.7	81.0	83.7	84.6	86.8	85.5	87.6	86.4	88.4	87.0	88.9
750	30	Input kW, Thermal	2.99	3.46	4.91	5.71	8.53	10.0	12.3	14.4	18.2	21.4	22.7	26.7
		Output Torque Nm, Thermal	733	884	1243	1499	2222	2681	3235	3903	4843	5843	6078	7332
		Input kW, Mechanical	2.72	2.93	3.78	4.09	5.25	5.72	8.36	9.11	12.4	13.5	17.6	19.2
		Output Torque Nm, Mechanical	667	747	955	1070	1364	1528	2195	2458	3292	3687	4710	5275
		Efficiency %	77.0	80.1	79.4	82.3	83.2	85.6	84.2	86.5	85.1	87.2	85.7	87.8
500	20	Input kW, Thermal	2.42	2.79	3.93	4.56	6.71	7.85	9.52	11.1	13.9	16.3	17.1	20.1
		Output Torque Nm, Thermal	860	1038	1449	1748	2561	3091	3673	4432	5420	6541	6730	8121
		Input kW, Mechanical	2.11	2.26	2.92	3.14	4.03	4.37	6.5	7.07	9.68	10.5	13.7	14.9
		Output Torque Nm, Mechanical	749	839	1073	1202	1532	1716	2503	2803	3766	4217	5356	5999
		Efficiency %	74.5	77.8	77.1	80.2	81.3	83.9	82.3	84.8	83.1	85.6	83.8	86.2
250	10	Input kW, Thermal	1.85	2.12	2.96	3.41	4.94	5.74	6.84	7.97	9.78	11.4	11.8	13.8
		Output Torque Nm, Thermal	1243	1499	2076	2505	3616	4366	5066	6116	7313	8829	8924	10773
		Input kW, Mechanical	1.33	1.41	1.83	1.96	2.51	2.56	4.06	4.38	6.06	6.55	8.56	9.27
		Output Torque Nm, Mechanical	894	1001	1280	1434	1831	1943	2997	3357	4518	5061	6442	7215
		Efficiency %	70.3	74.1	73.3	76.7	78.0	81.0	78.9	81.9	79.7	82.6	80.4	83.2

For details of unit designation code see page 13.

 IMPORTANT	Units to ATEX approval must be selected with a minimum service factor of 1.25.
--	--

RENOLD PM Series - PW Type - Speed Reducer - Selection Data

Mineral and Synthetic Oils

Nominal ratio: 35/1 (THIS RATIO MADE TO ORDER ONLY)

Input rpm	Output rpm	Product Code Centre Distance Gear Ratings	PW3REDXXX35***		PW4REDXXX35***		PW5REDXXX35***		PW6REDXXX35***		PW7REDXXX35***		PW8REDXXX35***	
			3.5"		4"		5"		6"		7"		8"	
			Min	Syn	Min	Syn	Min	Syn	Min	Syn	Min	Syn	Min	Syn
1800	51.4	Input kW, Thermal	4.49	5.21	7.68	8.97	12.1	14.2	18.3	21.5	27.8	32.7	35.8	42.1
		Output Torque Nm, Thermal	654	789	1162	1402	1873	2258	2867	3455	4403	5308	5725	5537
		Input kW, Mechanical	3.10	3.35	4.59	4.98	8.29	9.02	12.8	13.9	18.0	19.7	24.8	27.2
		Output Torque Nm, Mechanical	451	505	690	773	1273	1426	1990	2229	2840	3181	3957	4432
		Efficiency %	78.3	81.2	81.0	83.6	82.7	85.2	84.0	86.3	84.9	87.1	85.8	87.9
1500	42.9	Input kW, Thermal	3.97	4.61	6.78	7.90	10.6	12.4	15.9	18.7	24.1	28.3	31.0	36.5
		Output Torque Nm, Thermal	686	827	1214	1463	1943	2343	2962	3571	4539	5473	5898	7110
		Input kW, Mechanical	2.79	3.01	4.13	4.47	7.39	8.03	11.4	12.4	16.1	17.6	22.2	24.2
		Output Torque Nm, Mechanical	480	538	736	824	1347	1508	2111	2364	3023	3386	4208	4713
		Efficiency %	77.1	80.2	79.9	82.7	81.8	84.3	83.2	85.5	84.1	86.4	85.1	87.2
1200	34.3	Input kW, Thermal	3.37	3.90	5.71	6.64	8.86	10.3	13.2	15.4	19.9	23.3	25.4	29.8
		Output Torque Nm, Thermal	713	860	1257	1515	1994	2404	3020	3642	4604	5552	5965	7192
		Input kW, Mechanical	2.46	2.64	3.62	3.91	6.54	7.08	10.0	10.9	14.1	15.3	19.2	20.9
		Output Torque Nm, Mechanical	518	581	793	888	1466	1642	2291	2566	3251	3641	4486	5024
		Efficiency %	75.7	78.9	78.6	81.5	80.5	83.2	82.0	84.5	83.0	85.4	84.0	86.3
1000	28.6	Input kW, Thermal	2.98	3.44	5.02	5.83	7.73	9.00	11.4	13.3	17.1	20.0	21.8	25.5
		Output Torque Nm, Thermal	744	897	1307	1577	2058	2482	3099	3737	4698	5665	6067	7315
		Input kW, Mechanical	2.2	2.36	3.24	3.49	5.8	6.27	8.97	9.72	12.7	13.8	17.4	19.0
		Output Torque Nm, Mechanical	548	614	840	941	1540	1725	2427	2718	3482	3900	4838	5418
		Efficiency %	74.4	77.8	77.5	80.6	79.5	82.3	81.0	83.6	82.0	84.5	83.1	85.5
750	21.4	Input kW, Thermal	2.51	2.89	4.19	4.85	6.36	7.38	9.30	10.8	13.8	16.1	17.4	20.4
		Output Torque Nm, Thermal	813	980	1421	1714	2208	2663	3291	3969	4941	5958	6340	7646
		Input kW, Mechanical	1.87	1.99	2.73	2.94	4.91	5.29	7.5	8.11	10.6	11.5	14.5	15.8
		Output Torque Nm, Mechanical	603	675	922	1033	1700	1904	2650	2968	3788	4242	5281	5915
		Efficiency %	72.5	76.0	75.8	79.0	77.7	80.8	79.3	82.1	80.3	83.1	81.5	84.1
500	14.3	Input kW, Thermal	2.05	2.35	3.39	3.90	5.04	5.83	7.26	8.41	10.6	12.3	13.3	15.4
		Output Torque Nm, Thermal	958	1156	1666	2010	2543	3068	3737	4508	5529	6669	7026	8475
		Input kW, Mechanical	1.45	1.54	2.11	2.25	3.79	4.07	5.84	6.29	8.27	8.92	11.3	12.2
		Output Torque Nm, Mechanical	674	755	1032	1156	1906	2135	3003	3363	4308	4825	5991	6710
		Efficiency %	69.8	73.5	73.3	76.8	75.3	78.5	76.9	80.0	77.9	80.9	79.2	82.0
250	7.1	Input kW, Thermal	1.59	1.81	2.59	2.96	3.76	4.31	5.29	6.08	7.55	8.70	9.29	10.7
		Output Torque Nm, Thermal	1395	1683	2409	2906	3585	4325	5157	6222	7460	9000	9336	11264
		Input kW, Mechanical	0.91	0.96	1.31	1.39	2.36	2.52	3.65	3.90	5.17	5.54	7.08	7.59
		Output Torque Nm, Mechanical	795	891	1217	1363	2251	2521	3551	3977	5103	5715	7107	7960
		Efficiency %	65.4	69.5	69.3	73.1	71.2	74.9	72.8	76.3	73.8	77.2	75.1	78.4

For details of unit designation code see page 13.



Units to ATEX approval must be selected with a minimum service factor of 1.25.

RENOLD PM Series - PW Type - Speed Reducer - Selection Data

Mineral and Synthetic Oils

Nominal ratio: 40/1 Preferred Ratio

Input rpm	Output rpm	Product Code Centre Distance Gear Ratings	PW3REDXXX40***		PW4REDXXX40***		PW5REDXXX40***		PW6REDXXX40***		PW7REDXXX40***		PW8REDXXX40***	
			3.5"		4"		5"		6"		7"		8"	
			Min	Syn	Min	Syn	Min	Syn	Min	Syn	Min	Syn	Min	Syn
1800	45	Input kW, Thermal	4.08	4.86	6.93	8.07	11.0	12.9	16.4	19.1	25.3	29.5	32.1	37.6
		Output Torque Nm, Thermal	685	827	1170	1411	1912	2305	2863	3451	4480	5402	5749	6930
		Input kW, Mechanical	2.62	2.82	3.79	4.10	6.81	7.38	10.9	11.9	16.1	17.5	21.7	23.7
		Output Torque Nm, Mechanical	426	477	634	710	1169	1310	1899	2127	2846	3188	3879	4344
		Efficiency %	76.6	79.7	78.8	81.7	80.9	83.6	82.1	84.6	83.4	85.7	84.1	86.4
1500	37.5	Input kW, Thermal	3.72	4.30	6.13	7.11	9.69	11.3	14.3	16.6	21.9	25.6	27.8	32.6
		Output Torque Nm, Thermal	719	866	1222	1473	1984	2391	2959	3567	4617	5566	5920	7136
		Input kW, Mechanical	2.40	2.57	3.45	3.72	6.13	6.64	9.72	10.6	14.3	15.6	19.3	21.1
		Output Torque Nm, Mechanical	460	516	683	765	1248	1398	2009	2250	3007	3367	4105	4597
		Efficiency %	75.5	78.7	77.7	80.7	79.9	82.7	81.1	83.7	82.5	84.9	83.3	85.7
1200	30	Input kW, Thermal	3.16	3.65	5.17	5.99	8.10	9.42	11.8	13.8	18.0	21.1	22.8	26.7
		Output Torque Nm, Thermal	748	902	1265	1525	2036	2454	3017	3637	4681	5644	5986	7217
		Input kW, Mechanical	2.08	2.23	3.00	3.23	5.38	5.81	8.60	9.31	12.6	13.7	16.8	18.3
		Output Torque Nm, Mechanical	490	549	729	817	1346	1508	2187	2450	3264	3656	4405	4934
		Efficiency %	73.9	77.3	76.3	79.5	78.6	81.5	79.9	82.6	81.3	83.9	82.2	84.7
1000	25	Input kW, Thermal	2.80	3.22	4.56	5.27	7.07	8.21	10.3	11.9	15.6	18.1	19.6	22.9
		Output Torque Nm, Thermal	781	942	1316	1587	2102	2534	3095	3732	4777	5760	6088	7340
		Input kW, Mechanical	1.88	2.01	2.69	2.89	4.76	5.14	7.66	8.28	11.3	12.3	15.2	16.5
		Output Torque Nm, Mechanical	522	584	773	866	1410	1579	2305	2582	3468	3884	4722	5289
		Efficiency %	72.7	76.2	75.2	78.4	77.5	80.5	78.8	81.7	80.2	82.9	81.2	83.8
750	18.8	Input kW, Thermal	2.37	2.71	3.81	4.39	5.84	6.75	8.37	9.70	12.6	14.6	15.7	18.3
		Output Torque Nm, Thermal	855	1031	1430	1725	2257	2721	3287	3964	5026	6061	6363	7672
		Input kW, Mechanical	1.59	1.69	2.28	2.44	4.06	4.37	6.44	6.94	9.46	10.2	12.7	13.8
		Output Torque Nm, Mechanical	573	642	852	955	1566	1754	2525	2828	3777	4231	5145	5763
		Efficiency %	70.7	74.4	73.3	76.7	75.7	78.9	76.9	80.0	78.4	81.4	79.5	82.3
500	12.5	Input kW, Thermal	1.94	2.21	3.09	3.54	4.65	5.35	6.56	7.56	9.70	11.2	12.0	13.9
		Output Torque Nm, Thermal	1011	1219	1677	2022	2602	3138	3732	4501	5630	6790	7054	8507
		Input kW, Mechanical	1.23	1.30	1.75	1.87	3.11	3.33	5.00	5.36	7.37	7.91	9.89	10.6
		Output Torque Nm, Mechanical	638	714	947	1061	1738	1946	2839	3180	4268	4781	5809	6506
		Efficiency %	68.0	71.9	70.7	74.4	73.1	76.5	74.3	77.7	75.9	79.1	76.9	80.0
250	6.3	Input kW, Thermal	1.51	1.71	2.37	2.70	3.48	3.98	4.80	5.50	6.95	7.98	8.45	9.71
		Output Torque Nm, Thermal	1479	1784	2424	2925	3675	4433	5150	6212	7612	9182	9380	11315
		Input kW, Mechanical	0.77	0.81	1.10	1.16	1.96	2.08	3.15	3.35	4.64	4.95	6.24	6.66
		Output Torque Nm, Mechanical	751	841	1117	1252	2059	2306	3370	3774	5073	5682	6916	7746
		Efficiency %	63.7	67.8	66.5	70.5	68.9	72.7	70.0	73.8	71.5	75.2	72.6	76.1

For details of unit designation code see page 13.



IMPORTANT

Units to ATEX approval must be selected with a minimum service factor of 1.25.

RENOLD PM Series - PW Type - Speed Reducer - Selection Data

Mineral and Synthetic Oils

Nominal ratio: 45/1 (THIS RATIO MADE TO ORDER ONLY)

Input rpm	Output rpm	Product Code Centre Distance Gear Ratings	PW3REDXXX45***		PW4REDXXX45***		PW5REDXXX45***		PW6REDXXX45***		PW7REDXXX45***		PW8REDXXX45***	
			3.5"		4"		5"		6"		7"		8"	
			Min	Syn	Min	Syn	Min	Syn	Min	Syn	Min	Syn	Min	Syn
1800	40	Input kW, Thermal	4.00	4.62	6.52	7.58	10.4	12.1	15.0	17.6	22.1	25.7	28.7	33.5
		Output Torque Nm, Thermal	725	875	1218	1467	1992	2400	2910	3509	4297	5179	5523	6834
		Input kW, Mechanical	2.31	2.48	3.31	3.57	5.89	6.37	9.31	10.1	13.7	14.7	19.4	20.8
		Output Torque Nm, Mechanical	416	466	612	686	1119	1253	1788	2001	2653	2931	3806	4208
		Efficiency %	75.4	78.6	77.4	80.4	79.6	82.4	80.5	83.1	81.0	83.6	82.3	84.8
1500	33.3	Input kW, Thermal	3.55	4.10	5.77	6.68	9.12	10.6	13.1	15.3	19.2	22.4	24.9	29.1
		Output Torque Nm, Thermal	761	917	1271	1533	2066	2491	3008	3626	4432	5342	5841	7041
		Input kW, Mechanical	2.09	2.24	3.00	3.23	5.32	5.75	8.31	8.99	12.2	13.2	17.2	18.7
		Output Torque Nm, Mechanical	444	498	655	734	1198	1341	1892	2119	2791	3126	4016	4498
		Efficiency %	74.2	77.5	76.3	79.4	78.6	81.5	79.4	82.2	80.0	82.8	81.4	84.0
1200	26.7	Input kW, Thermal	3.02	3.48	4.88	5.63	7.63	8.85	10.9	12.7	15.9	18.5	20.5	23.9
		Output Torque Nm, Thermal	792	955	1317	1588	2121	2557	3067	3697	4496	5420	5909	7123
		Input kW, Mechanical	1.81	1.93	2.58	2.77	4.63	4.99	7.36	7.95	10.8	11.6	15.1	16.4
		Output Torque Nm, Mechanical	470	527	692	775	1279	1433	2060	2307	3037	3402	4337	4857
		Efficiency %	72.6	76.1	74.8	78.1	77.2	80.2	78.1	81.1	78.7	81.6	80.2	82.9
1000	22.2	Input kW, Thermal	2.68	3.08	4.30	4.96	6.67	7.72	9.48	11.00	13.7	15.9	17.6	20.5
		Output Torque Nm, Thermal	828	998	1371	1653	2191	2641	3147	3794	4588	5531	6009	7245
		Input kW, Mechanical	1.64	1.75	2.35	2.52	4.13	4.44	6.57	7.08	9.66	10.4	13.6	14.7
		Output Torque Nm, Mechanical	504	565	743	832	1350	1512	2173	2434	3217	3603	4620	5174
		Efficiency %	71.4	75.0	73.6	77.0	76.0	79.2	76.9	80.0	77.5	80.6	79.1	81.9
750	16.7	Input kW, Thermal	2.27	2.59	3.61	4.14	5.51	6.36	7.75	8.95	11.1	12.8	14.2	16.4
		Output Torque Nm, Thermal	906	1093	1492	1799	2354	2838	3344	4032	4824	5816	6280	7571
		Input kW, Mechanical	1.39	1.47	1.98	2.11	3.51	3.76	5.53	5.94	8.10	8.70	11.4	12.2
		Output Torque Nm, Mechanical	551	617	813	911	1493	1672	2378	2663	3509	3930	5030	5634
		Efficiency %	69.4	73.1	71.7	75.3	74.2	77.5	75.0	78.3	75.6	78.8	77.2	80.3
500	11.1	Input kW, Thermal	1.86	2.12	2.93	3.35	4.40	5.05	6.09	7.00	8.60	9.90	10.9	12.5
		Output Torque Nm, Thermal	1072	1293	1752	2113	2718	3278	3799	4582	5395	6505	6958	8390
		Input kW, Mechanical	1.07	1.13	1.52	1.61	2.67	2.85	4.27	4.56	6.30	6.74	8.83	9.46
		Output Torque Nm, Mechanical	611	684	900	1008	1643	1840	2653	2971	3942	4415	5653	6331
		Efficiency %	66.6	70.6	69.1	72.9	71.5	75.1	72.3	75.9	72.8	76.3	74.5	77.8
250	5.6	Input kW, Thermal	1.46	1.65	2.27	2.57	3.31	3.77	4.48	5.11	6.20	7.07	7.68	8.79
		Output Torque Nm, Thermal	1570	1894	2541	3065	3847	4640	5250	6333	7270	8768	9242	11147
		Input kW, Mechanical	0.67	0.71	0.95	1.00	1.69	1.78	2.70	2.86	4.02	4.26	5.62	5.98
		Output Torque Nm, Mechanical	720	806	1063	1190	1951	2185	3156	3535	4702	5267	6751	7561
		Efficiency %	62.3	66.5	64.9	69.0	67.3	71.2	67.9	71.8	68.1	72.0	69.9	73.6

For details of unit designation code see page 13.



IMPORTANT

Units to ATEX approval must be selected with a minimum service factor of 1.25.

RENOLD PM Series - PW Type - Speed Reducer - Selection Data

Mineral and Synthetic Oils

Nominal ratio: 50/1 Preferred Ratio

Input rpm	Output rpm	Product Code Centre Distance Gear Ratings	PW3REDXXX50***		PW4REDXXX50***		PW5REDXXX50***		PW6REDXXX50***		PW7REDXXX50***		PW8REDXXX50***	
			3.5"		4"		5"		6"		7"		8"	
			Min	Syn	Min	Syn	Min	Syn	Min	Syn	Min	Syn	Min	Syn
1800	36	Input kW, Thermal	3.81	4.40	6.16	7.14	9.49	11.0	13.9	16.3	21.2	24.7	26.7	31.1
		Output Torque Nm, Thermal	743	895	1259	1517	1973	2379	2953	3560	4532	5462	5757	6940
		Input kW, Mechanical	2.07	2.19	2.93	3.10	5.11	5.45	8.10	8.65	12.0	12.7	17.0	17.9
		Output Torque Nm, Mechanical	399	440	591	649	1053	1164	1696	1875	2558	2781	3640	3964
		Efficiency %	74.2	77.4	76.0	79.1	77.6	80.6	78.9	81.7	80.1	82.8	80.9	83.5
1500	30	Input kW, Thermal	3.39	3.91	5.46	6.31	8.34	9.66	12.2	14.2	18.4	21.4	23.2	27.0
		Output Torque Nm, Thermal	779	939	1314	1584	2048	2469	3051	3678	4668	5627	5929	7147
		Input kW, Mechanical	1.86	1.99	2.63	2.83	4.64	4.99	7.32	7.89	10.7	11.6	15.1	16.3
		Output Torque Nm, Mechanical	423	474	627	702	1129	1265	1812	2030	2700	3024	3837	4298
		Efficiency %	72.9	76.3	74.8	78.1	76.5	79.6	77.8	80.8	79.0	81.9	79.9	82.7
1200	24	Input kW, Thermal	2.89	3.32	4.62	5.33	6.99	8.07	10.2	11.8	15.2	17.7	19.1	22.2
		Output Torque Nm, Thermal	811	978	1362	1642	2102	2534	3111	3750	4733	5706	5996	7228
		Input kW, Mechanical	1.62	1.73	2.29	2.45	4.04	4.33	6.44	6.93	9.51	10.3	13.3	14.4
		Output Torque Nm, Mechanical	451	505	667	747	1205	1349	1957	2192	2939	3292	4166	4666
		Efficiency %	71.3	74.9	73.3	76.7	75.0	78.3	76.4	79.5	77.7	80.7	78.6	81.5
1000	20	Input kW, Thermal	2.57	2.94	4.08	4.70	6.12	7.05	8.84	10.2	13.2	15.2	16.4	19.1
		Output Torque Nm, Thermal	848	1022	1419	1711	2171	2618	3192	3849	4830	5823	6098	7352
		Input kW, Mechanical	1.47	1.57	2.07	2.22	3.61	3.87	5.75	6.18	8.49	9.13	11.9	12.8
		Output Torque Nm, Mechanical	483	541	714	800	1272	1425	2067	2315	3099	3471	4406	4935
		Efficiency %	70	73.7	72.1	75.6	73.8	77.2	75.2	78.5	76.5	79.6	77.5	80.5
750	15	Input kW, Thermal	2.18	2.48	3.43	3.93	5.07	5.82	7.24	8.34	10.7	12.3	13.2	15.3
		Output Torque Nm, Thermal	929	1120	1546	1864	2333	2813	3393	4091	5083	6128	6374	7684
		Input kW, Mechanical	1.24	1.31	1.74	1.85	3.06	3.27	4.84	5.18	7.12	7.64	10.0	10.8
		Output Torque Nm, Mechanical	525	588	776	869	1400	1568	2258	2529	3379	3785	4817	5395
		Efficiency %	68	71.9	70.2	73.9	71.9	75.4	73.2	76.7	74.5	77.8	75.5	78.8
500	10	Input kW, Thermal	1.79	2.03	2.80	3.19	4.06	4.64	5.71	6.54	8.29	9.52	10.2	11.7
		Output Torque Nm, Thermal	1100	1327	1818	2192	2694	3249	3858	4652	5695	6867	7065	8519
		Input kW, Mechanical	0.95	1.00	1.33	1.41	2.32	2.47	3.72	3.96	5.52	5.88	7.74	8.27
		Output Torque Nm, Mechanical	580	650	857	960	1533	1717	2504	2804	3776	4229	5372	6017
		Efficiency %	65.2	69.3	67.5	71.4	69.1	72.9	70.4	74.1	71.7	75.3	72.7	76.2
250	5	Input kW, Thermal	1.41	1.59	2.17	2.46	3.07	3.48	4.22	4.80	6.00	6.83	7.22	8.24
		Output Torque Nm, Thermal	1614	1947	2643	3188	3814	4600	5337	6436	7705	9293	9393	11328
		Input kW, Mechanical	0.60	0.63	0.84	0.88	1.48	1.56	2.37	2.50	3.53	3.73	4.96	5.25
		Output Torque Nm, Mechanical	684	766	1012	1133	1825	2044	2985	3343	4510	5051	6429	7200
		Efficiency %	60.9	65.2	63.3	67.5	64.7	68.8	65.9	69.9	67.0	71.0	67.9	71.8

For details of unit designation code see page 13.



IMPORTANT

Units to ATEX approval must be selected with a minimum service factor of 1.25.

RENOLD PM Series - PW Type - Speed Reducer - Selection Data

Mineral and Synthetic Oils

Nominal ratio: 60/1 Preferred Ratio

Input rpm	Output rpm	Product Code Centre Distance Gear Ratings	PW3REDXXX60***		PW4REDXXX60***		PW5REDXXX60***		PW6REDXXX60***		PW7REDXXX60***		PW8REDXXX60***	
			3.5"		4"		5"		6"		7"		8"	
			Min	Syn	Min	Syn	Min	Syn	Min	Syn	Min	Syn	Min	Syn
1800	30	Input kW, Thermal	3.31	3.78	5.58	6.44	8.59	9.9	12.7	14.6	19.1	22.2	24.1	28.0
		Output Torque Nm, Thermal	748	901	1323	1595	2084	2512	3112	3752	4783	5766	6089	7339
		Input kW, Mechanical	1.60	1.62	2.30	2.35	4.03	4.14	6.32	6.54	9.34	9.65	13.1	13.5
		Output Torque Nm, Mechanical	356	379	536	571	964	1029	1537	1653	2310	2475	3287	3496
		Efficiency %	70.0	73.6	73.2	76.4	75.1	78.2	76.4	79.4	77.7	80.6	78.6	81.4
1500	25	Input kW, Thermal	2.95	3.37	4.95	5.69	7.56	8.72	11.1	12.8	16.7	19.3	20.9	24.3
		Output Torque Nm, Thermal	784	945	1383	1667	2161	2605	3214	3874	4923	5934	6261	7546
		Input kW, Mechanical	1.42	1.51	2.05	2.18	3.63	3.83	5.75	6.08	8.44	8.98	11.8	12.6
		Output Torque Nm, Mechanical	373	417	563	629	1023	1129	1652	1821	2470	2734	3491	3882
		Efficiency %	68.7	72.4	72.0	75.4	73.9	77.2	75.3	78.4	76.6	79.7	77.6	80.6
1200	20	Input kW, Thermal	2.52	2.88	4.20	4.82	6.35	7.31	9.21	10.6	13.8	15.9	17.3	20.0
		Output Torque Nm, Thermal	817	985	1435	1730	2220	2676	3278	3951	4990	6015	6326	7625
		Input kW, Mechanical	1.26	1.33	1.81	1.92	3.17	3.38	5.01	5.37	7.39	7.93	10.4	11.2
		Output Torque Nm, Mechanical	403	451	608	680	1094	1225	1766	1978	2651	2969	3779	4232
		Efficiency %	67.0	70.9	70.5	74.1	72.3	75.8	73.8	77.1	75.2	78.4	76.2	79.3
1000	16.7	Input kW, Thermal	2.25	2.56	3.72	4.26	5.58	6.40	8.03	9.24	11.9	13.8	14.9	17.2
		Output Torque Nm, Thermal	855	1031	1496	1804	2295	2767	3365	4057	5093	6140	6433	7755
		Input kW, Mechanical	1.14	1.20	1.63	1.73	2.84	3.03	4.49	4.80	6.61	7.08	9.22	9.89
		Output Torque Nm, Mechanical	428	479	645	722	1158	1297	1866	2090	2798	3134	3959	4434
		Efficiency %	65.6	69.6	69.2	72.9	71.1	74.7	72.5	76.0	73.9	77.3	75.0	78.2
750	12.5	Input kW, Thermal	1.91	2.17	3.14	3.58	4.64	5.30	6.60	7.57	9.71	11.2	12.0	13.8
		Output Torque Nm, Thermal	938	1131	1632	1968	2469	2977	3581	4318	5365	6468	6728	8110
		Input kW, Mechanical	0.95	1.00	1.35	1.43	2.39	2.54	3.77	4.02	5.53	5.90	7.79	8.33
		Output Torque Nm, Mechanical	460	515	693	776	1260	1411	2032	2276	3037	3401	4343	4865
		Efficiency %	63.5	67.6	67.2	71.1	69.1	72.8	70.5	74.1	71.9	75.4	72.9	76.4
500	8.3	Input kW, Thermal	1.59	1.79	2.58	2.92	3.73	4.25	5.23	5.97	7.58	8.67	9.28	10.6
		Output Torque Nm, Thermal	1113	1341	1925	2321	2858	3446	4081	4921	6024	7263	7471	9008
		Input kW, Mechanical	0.73	0.76	1.03	1.09	1.81	1.91	2.88	3.05	4.28	4.54	6.02	6.41
		Output Torque Nm, Mechanical	507	567	764	855	1374	1539	2230	2498	3380	3785	4831	5411
		Efficiency %	60.6	64.9	64.5	68.6	66.2	70.2	67.6	71.5	68.9	72.7	70.0	73.7
250	4.2	Input kW, Thermal	1.26	1.41	2.01	2.27	2.85	3.21	3.90	4.41	5.54	6.27	6.66	7.55
		Output Torque Nm, Thermal	1636	1973	2811	3390	4061	4898	5670	6838	8183	9869	9973	12026
		Input kW, Mechanical	0.47	0.45	0.65	0.64	1.16	1.21	1.84	1.94	2.74	2.89	3.86	4.07
		Output Torque Nm, Mechanical	598	623	902	948	1636	1833	2662	2981	4032	4515	5760	6451
		Efficiency %	56.2	60.6	60.3	64.6	61.8	66.0	63.0	67.2	64.1	68.3	65.1	69.2

For details of unit designation code see page 13.



IMPORTANT

Units to ATEX approval must be selected with a minimum service factor of 1.25.

RENOLD PM Series - PW Type - Speed Reducer - Selection Data

Mineral and Synthetic Oils

Nominal ratio: 70/1 Preferred Ratio

Input rpm	Output rpm	Product Code Centre Distance Gear Ratings	PW3REDXXX70***		PW4REDXXX70***		PW5REDXXX70***		PW6REDXXX70***		PW7REDXXX70***		PW8REDXXX70***	
			3.5"		4"		5"		6"		7"		8"	
			Min	Syn	Min	Syn	Min	Syn	Min	Syn	Min	Syn	Min	Syn
1800	25.7	Input kW, Thermal	3.08	3.52	4.76	5.45	7.30	8.38	10.7	12.3	16.1	18.6	20.3	23.4
		Output Torque Nm, Thermal	789	951	1240	1495	1949	2349	2910	3507	4470	5388	5676	6841
		Input kW, Mechanical	1.36	1.35	1.92	1.90	3.34	3.32	5.23	5.24	7.64	7.66	10.8	10.8
		Output Torque Nm, Mechanical	342	357	489	508	877	913	1402	1468	2088	2184	2977	3110
		Efficiency %	67.7	71.3	68.6	72.1	70.6	74.0	72.1	75.4	73.6	76.8	74.6	77.7
1500	21.4	Input kW, Thermal	2.75	3.14	4.23	4.83	6.44	7.37	9.39	10.8	14.1	16.2	17.7	20.4
		Output Torque Nm, Thermal	828	998	1295	1561	2022	2437	3007	3625	4607	5553	5849	7050
		Input kW, Mechanical	1.22	1.26	1.72	1.77	3.01	3.08	4.75	4.88	6.97	7.19	9.72	10.1
		Output Torque Nm, Mechanical	361	393	516	560	929	1001	1500	1619	2250	2430	3181	3439
		Efficiency %	66.3	70.1	67.3	71.0	69.3	72.9	70.9	74.4	72.4	75.8	73.5	76.8
1200	17.1	Input kW, Thermal	2.36	2.68	3.61	4.10	5.43	6.20	7.85	8.98	11.7	13.4	14.6	16.8
		Output Torque Nm, Thermal	863	1041	1342	1617	2076	2502	3066	3696	4673	5632	5918	7133
		Input kW, Mechanical	1.08	1.14	1.51	1.59	2.63	2.79	4.12	4.38	6.09	6.49	8.54	9.12
		Output Torque Nm, Mechanical	389	436	552	618	992	1111	1590	1781	2402	2691	3422	3833
		Efficiency %	64.6	68.7	65.6	69.6	67.7	71.5	69.2	72.9	70.8	74.4	71.9	75.5
1000	14.3	Input kW, Thermal	2.11	2.39	3.20	3.63	4.78	5.44	6.86	7.83	10.2	11.6	12.7	14.5
		Output Torque Nm, Thermal	904	1090	1397	1684	2143	2583	3146	3793	4768	5747	6019	7255
		Input kW, Mechanical	0.97	1.00	1.36	1.44	2.36	2.5	3.74	3.97	5.5	5.84	7.67	8.17
		Output Torque Nm, Mechanical	411	451	585	656	1047	1172	1697	1901	2550	2856	3621	4055
		Efficiency %	63.3	67.3	64.2	68.3	66.3	70.2	67.9	71.7	69.4	73.1	70.6	74.2
750	10.7	Input kW, Thermal	1.80	2.03	2.71	3.06	3.99	4.52	5.66	6.43	8.31	9.47	10.3	11.7
		Output Torque Nm, Thermal	993	1197	1521	1834	2302	2775	3343	4030	5016	6046	6290	7581
		Input kW, Mechanical	0.81	0.80	1.14	1.19	1.99	2.10	3.13	3.30	4.60	4.87	6.47	6.86
		Output Torque Nm, Mechanical	438	466	629	700	1136	1272	1827	2046	2751	3081	3938	4411
		Efficiency %	61.1	65.3	62.1	66.2	64.0	68.1	65.6	69.6	67.1	71.0	68.3	72.1
500	7.1	Input kW, Thermal	1.50	1.68	2.23	2.51	3.23	3.63	4.51	5.10	6.53	7.39	7.97	9.04
		Output Torque Nm, Thermal	1180	1423	1788	2156	2656	3202	3798	4579	5616	6770	6968	8399
		Input kW, Mechanical	0.62	0.58	0.88	0.85	1.53	1.60	2.44	2.56	3.61	3.80	5.05	5.32
		Output Torque Nm, Mechanical	480	480	694	723	1247	1397	2035	2280	3082	3451	4392	4919
		Efficiency %	58.2	62.4	59.1	63.4	60.9	65.2	62.4	66.6	63.9	68.0	65.1	69.1
250	3.6	Input kW, Thermal	1.20	1.33	1.76	1.96	2.48	2.77	3.39	3.80	4.81	5.39	5.77	6.48
		Output Torque Nm, Thermal	1741	2100	2597	3132	3755	4527	5249	6329	7588	9149	9252	11154
		Input kW, Mechanical	0.35	0.32	0.52	0.48	0.98	0.91	1.57	1.53	2.32	2.40	3.25	3.39
		Output Torque Nm, Mechanical	503	503	756	756	1474	1475	2404	2533	3638	4053	5182	5804
		Efficiency %	53.7	58.1	54.5	58.9	56.1	60.5	57.4	61.8	58.7	63.1	59.7	64.1

For details of unit designation code see page 13.

IMPORTANT Units to ATEX approval must be selected with a minimum service factor of 1.25.

RENOLD PM Series - PW Type - Speed Reducer Dimensions

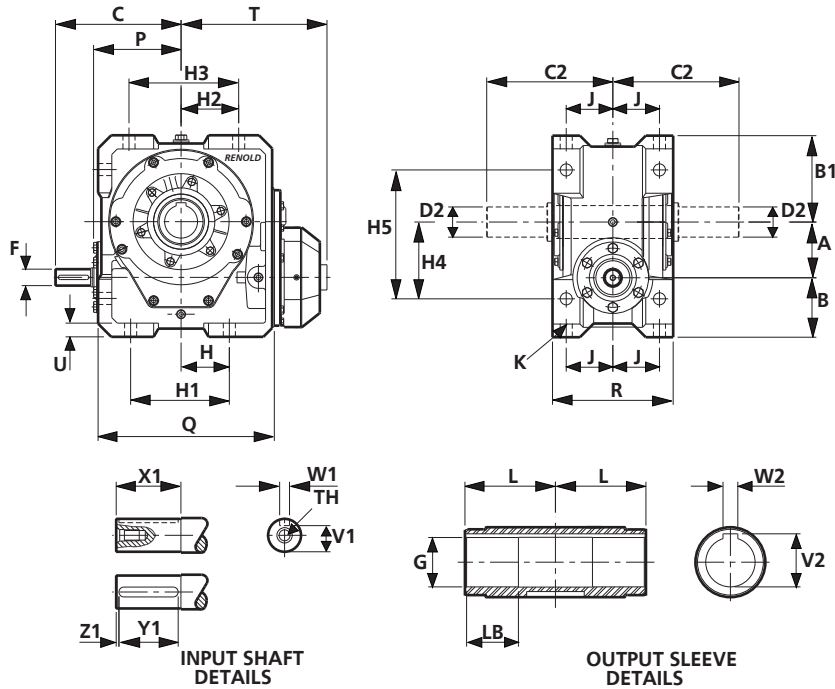

PM Series - PW Reduction Gear

UNIT REF	A (inch)	A (mm)	B	B1	C	H	H1	H2	H3	H4	H5
PW35	3.5	88.9	91.1	140.0	195	60	135	85	160	120	205
PW40	4.0	101.6	108.4	157.5	229	88	180	105	200	140	235
PW50	5.0	127	113.0	195.0	260	88	180	125	230	160	280
PW60	6.0	152.4	127.6	225.0	279	120	235	145	270	190	340
PW70	7.0	177.8	157.2	255.5	318	140	290	160	310	240	412
PW80	8.0	203.2	166.8	280.0	343	140	310	170	340	256	460

UNIT REF	J	K	P	Q	R	T	U
PW35	75	17.0	134	274	186	240	25
PW40	85	21.5	159	321	220	266	25
PW50	100	21.5	184	365	250	286	30
PW60	125	25.5	199	418	305	339	35
PW70	150	25.5	225	458	360	354	35
PW80	150	25.5	246	503	360	378	35

Input Shaft

UNIT REF	F	V1	W1	X1	Y1	Z1	TH
PW35	25j6	21.0	8P9	60	56	3	M10x22
PW40	30k6	26.0	8P9	64	56	5	M10x22
PW50	38k6	33.0	10P9	76	63	5	M12x28
PW60	45k6	39.5	14P9	76	63	5	M16x36
PW70	45k6	39.5	14P9	89	80	5	M16x36
PW80	50k6	44.5	14P9	95	80	5	M16x36

Plug-in Output Shaft

UNIT REF	C2	D2
PW35	220	45k6
PW40	230	55m6
PW50	280	65m6
PW60	305	75m6
PW70	355	85m6
PW80	355	95m6

Output Sleeve

UNIT REF	G	L	LB	V2	W2
PW35	50F7	103	55	53.8	14Js9
PW40	60F7	110	65	64.4	18Js9
PW50	70F7	130	70	74.9	20Js9
PW60	90F7	155	90	95.4	25Js9
PW70	100F7	174	115	106.4	28Js9
PW80	100F7	174	115	106.4	28Js9

RENOLD PM Series - PW Type - Speed Reducer Dimensions

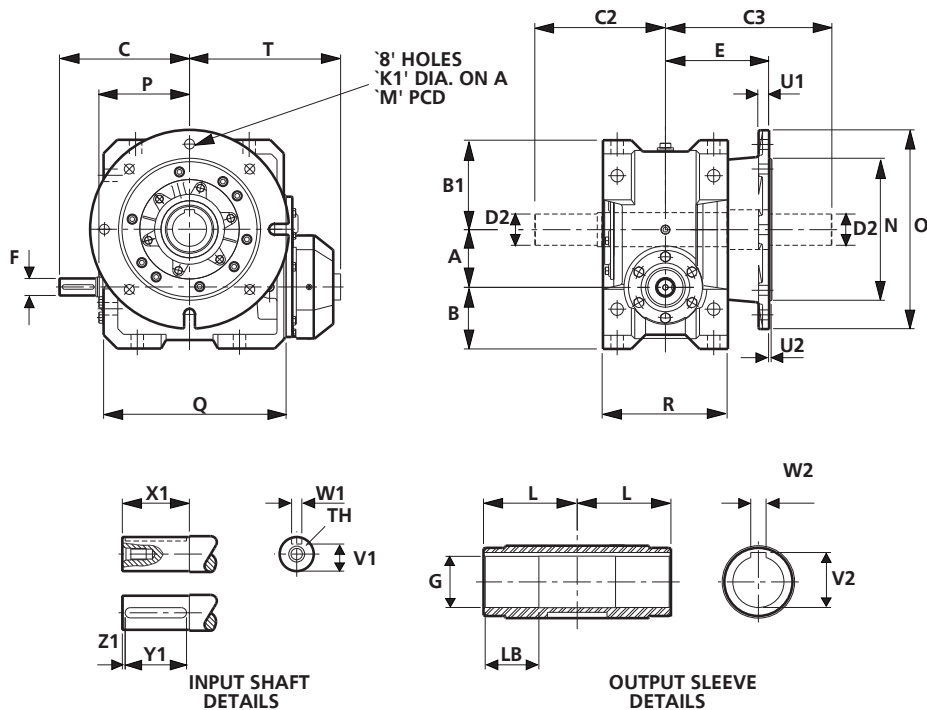

PM Series - PW Reduction Gear - (Horizontal Flange Mounted)

UNIT REF	A (inch)	A (mm)	B	B1	C	E	K1
PW35	3.5	88.9	91.1	140.0	195	154	13.5
PW40	4.0	101.6	108.4	157.5	229	183	17.5
PW50	5.0	127	113.0	195.0	260	197	17.5
PW60	6.0	152.4	127.6	225.0	279	215	17.5
PW70	7.0	177.8	157.2	255.5	318	248	17.5
PW80	8.0	203.2	166.8	280.0	343	248	17.5

UNIT REF	M	N	O	P	Q	R	T	U1	U2
PW35	265	230h8	300	134	274	186	240	13	4
PW40	300	250h8	350	159	321	220	266	19	5
PW50	350	300h8	400	184	365	250	286	19	5
PW60	400	350h8	450	199	418	305	339	19	5
PW70	500	450h8	550	225	458	360	354	24	5
PW80	500	450h8	550	246	503	360	378	24	5

Input Shaft

UNIT REF	F	V1	W1	X1	Y1	Z1	TH
PW35	25j6	21.0	8P9	60	56	3	M10x22
PW40	30k6	26.0	8P9	64	56	5	M10x22
PW50	38k6	33.0	10P9	76	63	5	M12x28
PW60	45k6	39.5	14P9	76	63	5	M16x36
PW70	45k6	39.5	14P9	89	80	5	M16x36
PW80	50k6	44.5	14P9	95	80	5	M16x36

Output Sleeve

UNIT REF	G	L	LB	V2	W2
PW35	50F7	103	55	53.8	14Js9
PW40	60F7	110	65	64.4	18Js9
PW50	70F7	130	70	74.9	20Js9
PW60	90F7	155	90	95.4	25Js9
PW70	100F7	174	115	106.4	28Js9
PW80	100F7	174	115	106.4	28Js9

Plug-in Output Shaft

UNIT REF	C2	C3	D2
PW35	220	264	45k6
PW40	230	293	55m6
PW50	280	337	65m6
PW60	305	355	75m6
PW70	355	418	85m6
PW80	355	418	95m6

RENOLD PM Series - PW Type - Speed Reducer Dimensions

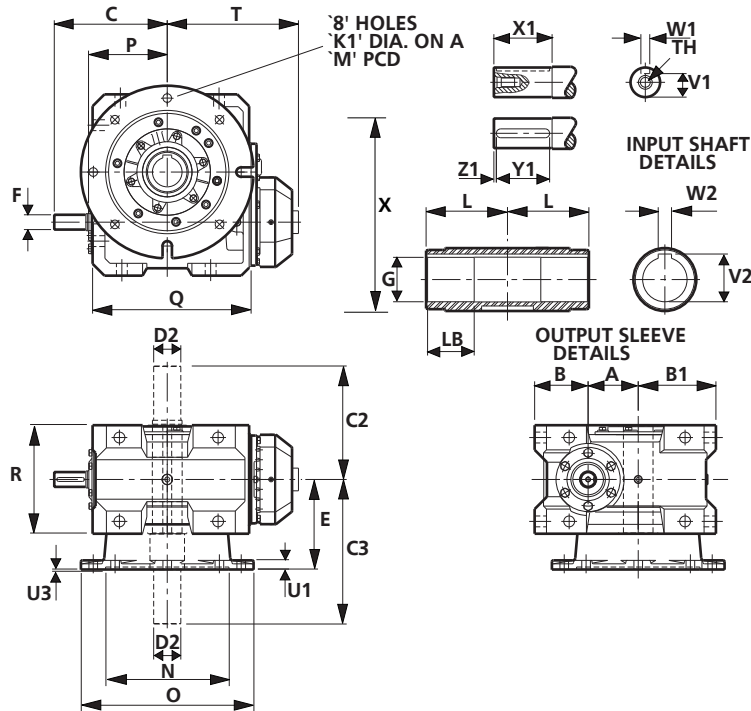

PM Series - PW Reduction Gear - (Vertical Skirt)

UNIT REF	A (inch)	A (mm)	B	B1	C	E	K1
PW35	3.5	88.9	91.1	140.0	195	154	13.5
PW40	4.0	101.6	108.4	157.5	229	183	17.5
PW50	5.0	127.0	113.0	195.0	260	197	17.5
PW60	6.0	152.4	127.6	225.0	279	215	17.5
PW70	7.0	177.8	157.2	255.5	318	248	17.5
PW80	8.0	203.2	166.8	280.0	343	248	17.5

UNIT REF	M	N	O	P	Q	R	T	U1	U3
PW35	265	230H8	300	134	274	186	240	13	5
PW40	300	250H8	350	159	321	220	266	19	6
PW50	350	300H8	400	184	365	250	286	19	6
PW60	400	350H8	450	199	418	305	339	19	6
PW70	500	450H8	550	225	458	360	354	24	6
PW80	500	450H8	550	246	503	360	378	24	6

Wormshaft

UNIT REF	F	V1	W1	X1	Y1	Z1	TH
PW35	25j6	21.0	8P9	60	56	3	M10x22
PW40	30k6	26.0	8P9	64	56	5	M10x22
PW50	38k6	33.0	10P9	76	63	5	M12x28
PW60	45k6	39.5	14P9	76	63	5	M16x36
PW70	45k6	39.5	14P9	89	80	5	M16x36
PW80	50k6	44.5	14P9	95	80	5	M16x36

Output Sleeve

UNIT REF	G	L	LB	V2	W2
PW35	50F7	103	55	53.8	14Js9
PW40	60F7	110	65	64.4	18Js9
PW50	70F7	130	70	74.9	20Js9
PW60	90F7	155	90	95.4	25Js9
PW70	100F7	174	115	106.4	28Js9
PW80	100F7	174	115	106.4	28Js9

Plug-in Output Shaft

UNIT REF	C2	C3	D2
PW35	220	264	45k6
PW40	230	293	55m6
PW50	280	337	65m6
PW60	305	355	75m6
PW70	355	418	85m6
PW80	355	418	95m6

RENOLD PM Series - PW Type - Output Shaft Dimensions

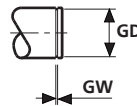
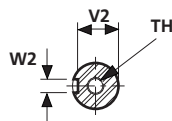
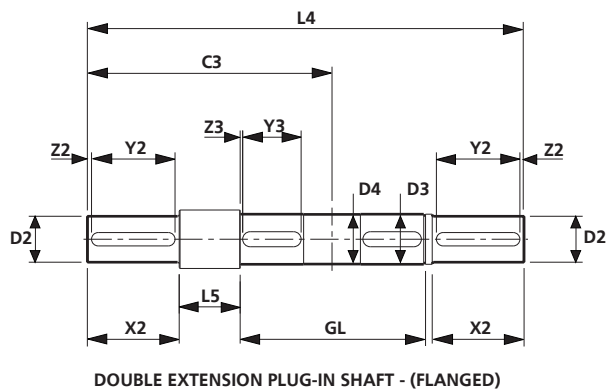
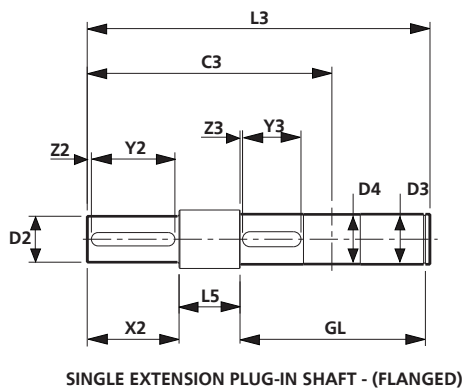
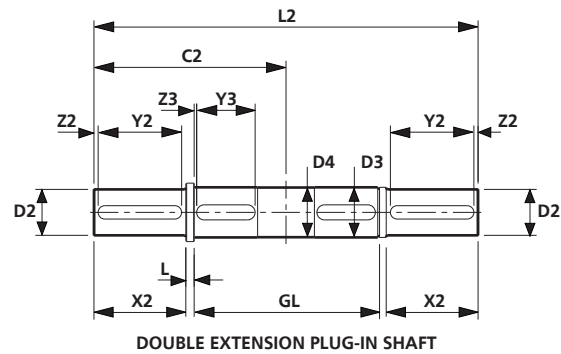
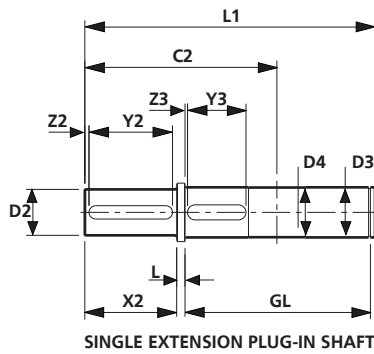

EXTENSION KEYWAY DETAILS CIRCLIP GROOVE DETAILS

Plug-in Shafts

UNIT REF	C2	C3	L	L1	L2	L3	L4	L5	GD	GL	GW
PW35	220	264	7	330.5	440	374.5	484	51	47.00	207.90	2.29
									46.75	207.85	2.15
PW40	230	293	10	347.5	460	410.5	523	73	57.00	222.15	2.29
									56.70	222.10	2.15
PW50	280	337	10	418.5	560	475.5	617	67	67.00	262.65	2.79
									66.70	262.60	2.65
PW60	305	355	10	469.5	610	519.5	660	60	86.50	313.15	3.33
									86.15	313.10	3.15
PW70	355	418	11	538.5	710	601.5	773	74	96.50	351.15	3.33
									96.15	351.10	3.15
PW80	355	418	11	538.5	710	601.5	773	74	96.50	351.15	3.33
									96.15	351.10	3.15

UNIT REF	D2	V2	W2	X2	Y2	Z2	TH	D3	Y3	Z3	D4
PW35	45k6	39.50	14P9	110	100	5	M16x36	50h6	63	3	46
PW40	55m6	49.00	16P9	110	100	5	M20x42	60h6	70	3	56
PW50	65m6	58.00	18P9	140	125	5	M20x42	70h6	90	2	66
PW60	75m6	67.50	20P9	140	125	5	M20x42	90h6	110	3	86
PW70	85m6	76.00	22P9	170	160	5	M20x42	100h6	125	3	96
PW80	95m6	86.00	25P9	170	160	5	M24x50	100h6	125	3	96

RENOLD PM Series - PW Type - Torque Restraint Bracket

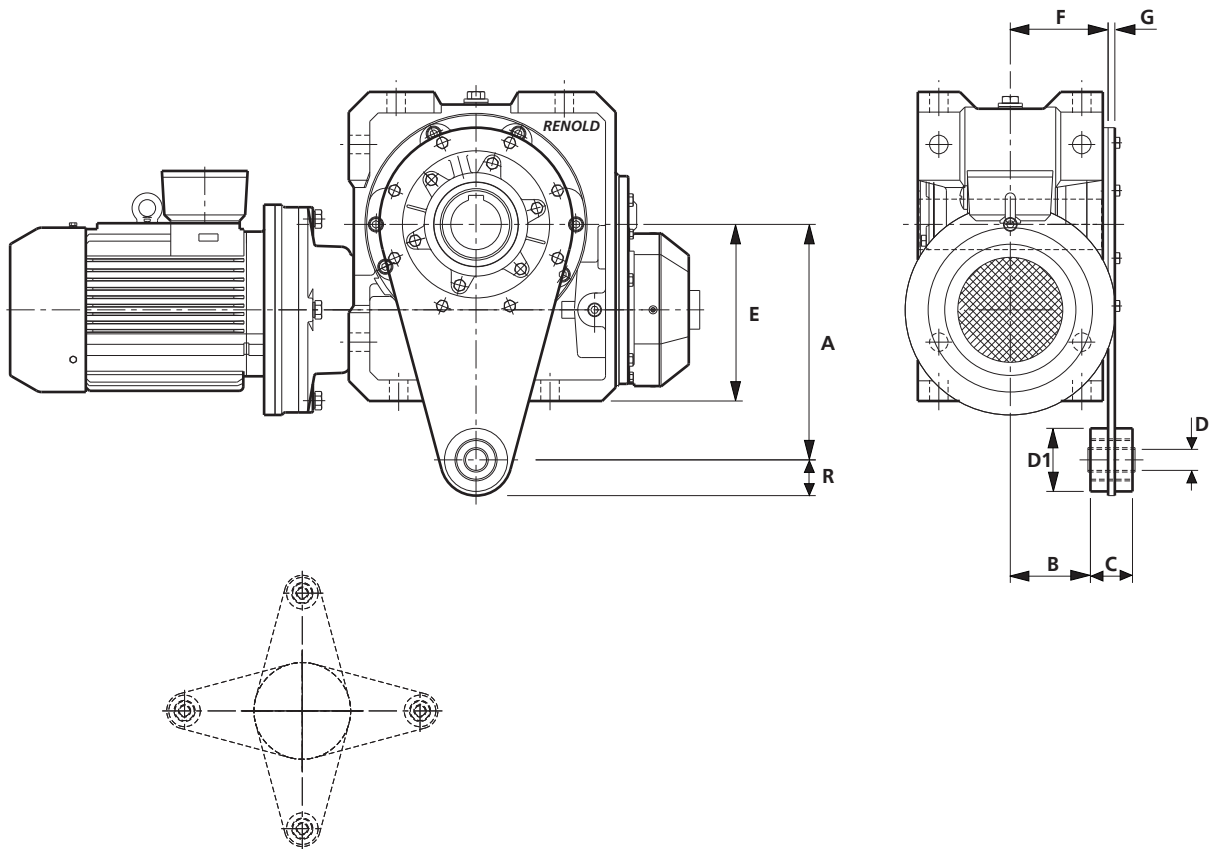

BRACKET CAN BE MOUNTED IN ANY OF 4 POSITIONS SHOWN
- ON EITHER SIDE OF GEAR UNIT

Torque Restraint Bracket

UNIT SIZE	A	B	C	D	D1	E	F	G	R
PW35	240	68.0	70	20	70	180	97	12	45
PW40	270	102.0	70	20	70	210	131	12	45
PW50	300	116.0	70	20	70	240	145	12	45
PW60	360	134.5	66	30	80	280	160	15	52
PW70	415	159.5	66	30	80	335	185	15	52
PW80	450	159.5	66	30	80	370	185	15	52

RENOLD PM Series - PW Type - Shrink Disc Dimensions

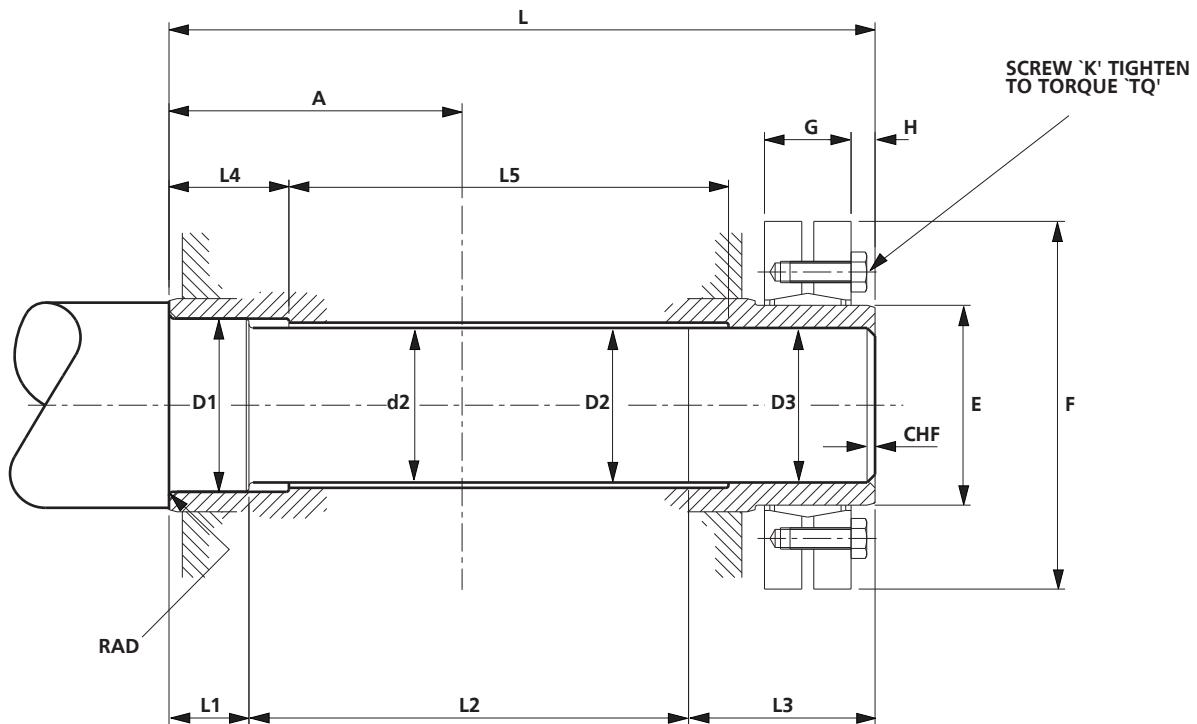

Shrink Disc

UNIT SIZE	Driven Shaft Details							
	D1	D2	D3	L1	L2	L3	RAD	CHF
PW35	52g6	50	50g6	25	140	80	1.5	2
PW40	65g6	60	60g6	30	150	85	1.5	3
PW50	75g6	70	70g6	35	180	95	1.5	3
PW60	90g6	85	85g6	40	220	115	2	3
PW70	100g6	95	95g6	45	250	135	2	3
PW80	100g6	95	95g6	45	250	135	2	3

UNIT SIZE	Hollow Shaft Details						
	A	D1	d2	D3	L	L4	L5
PW35	102.9	52H7	51	50H6	245	35	140
PW40	110	65H7	62	60H6	265	40	150
PW50	130	75H7	72	70H6	310	50	180
PW60	155	90H7	88	85H7	375	55	220
PW70	174	100H7	98	95H7	430	60	250
PW80	174	100H7	98	95H7	430	60	250

UNIT SIZE	Shrink Disc Details							Max. Torque Nm
	REF	E	F	G	H	K	TQ Nm	
PW35	62-4071	62	110	30.5	6	M6	12	1100
PW40	75-4071	75	138	32.5	9	M8	30	1600
PW50	90-4071	90	155	39	9	M8	30	3000
PW60	110-4071	110	185	50	12	M10	59	5400
PW70	125-4071	125	215	54	23	M10	59	7500
PW80	125-4071	125	215	54	23	M10	59	7500
	125-4091	125	215	65	12	M12	100	10000

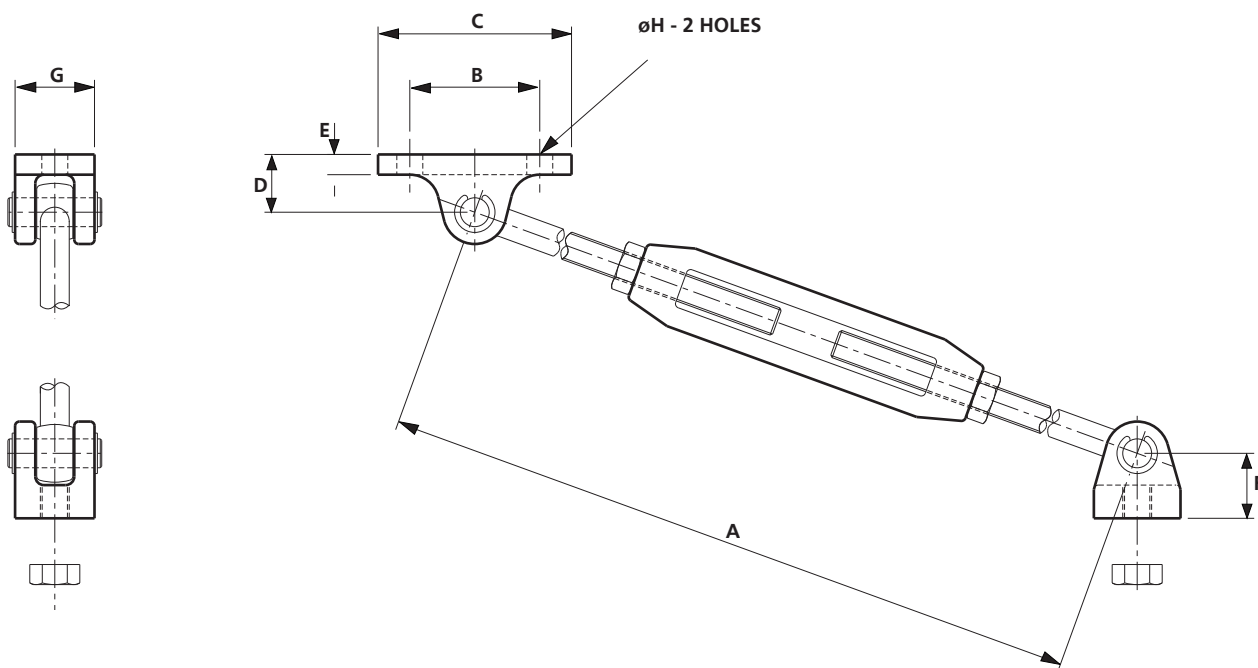

Torque Arm Assembly

UNIT SIZE	A	B	C	D	E	F	G	H
PW35	600	75	108	35	13	40	41	M12
	750							
PW40	600	90	133	40	14	45	52	M16
	750							
PW50	600	90	133	40	14	45	52	M16
	750							
PW60	760	115	178	57	21	55	76	M20
	910							
PW70	760	115	178	57	21	55	76	M20
	910							
PW80	760	115	178	57	21	55	76	M20
	910							

RENOLD PM Series - Installation, Maintenance & Storage

Initial Running

All units are supplied without oil.

First Filling

Single Reduction Units

When installed and before running, the unit should be filled with new lubricant to the correct level as follows.

With the gear stationary, remove the filler and breather plug and oil level plug. Fill until the lubricant level is visible at the indicator (if fitted) or until lubricant overflows from oil level aperture.

Replace and secure both plugs. Care should be taken to avoid overfilling, as this may cause subsequent leakage.

Starting Up

All units have been subjected to a short test before despatch to the customer but it takes many hours running under full load for the gear to attain its highest efficiency. The gear may if necessary be put to work immediately on full load, but if circumstances permit it is better for the ultimate life of the gear to run it in under gradually increasing load attaining the full load after about 20 to 40 hours.

Reasonable precautions should however, be taken to avoid overloads in the early stage of running. Temperature rise on the initial run will be higher than that eventually attained after the gear is fully run in.

Routine Maintenance

The oil level in the unit should be regularly maintained, and should be checked at least once a month. To avoid false readings, examination of the oil level should be made with the gear stationary, and to maintain free ventilation of the unit under all conditions, the breather hole in the filler plug should be kept clear at all times. In the case of double reduction units, ensure that maintenance requirements given above are applied to both 1st and 2nd stage reduction gears.

Changing Oil

The oil should be changed completely at intervals depending upon the working conditions.

Grease Lubrication of Bearings

Where this feature is included, the bearing caps are fitted with a grease nipple or stauffer lubricator, which should be used to lubricate the bearings.

When mounted with wormshafts vertical, the top bearing requires grease lubrication. Standard units, therefore, need to be modified by the inclusion of a grease nipple and nylos ring adjacent to the top bearing. Customers must advise us of this requirement when placing enquiries and orders.

Couplings and Bedplates

All couplings should be carefully fitted and shafts accurately aligned. To prevent damage to the bearings, coupling half-bodies should not be hammered onto shafts.

Worm gear units and other drive components should be rigidly mounted on firm foundations to prevent movement and vibration which may affect the alignment of the shafts. Suitable bedplates can be supplied if required.

Abnormal Ambient Temperatures

If the gear unit is to be operated under extremes of temperature or humidity, special oils may be required and recommendations will be made on request.

Storage

All worm gear units stored or left inactive for long periods should be adequately protected, particularly those on exposed sites and those operating in corrosive atmospheres.

The following precautions will generally be adequate, but advice on the protection of particular units will be given, if required.

If empty of oil: spray the gear case interior with rust preventative oil; compatible with lubricant recommended for service conditions. If filled with oil: operate at full speed once per month for not less than 10 minutes to ensure liberal coating of all internal parts with oil. For indefinite storage: completely fill unit with oil ensuring complete submersion of all internal components. Shafts should be occasionally turned by hand. When unit is returned to service, drain and refill with new oil to correct level.

External shaft extensions and oil seals can be protected by the use of grease impregnated tape. Full long term storage specification details can be obtained from Renold on request.

Spare Parts

Information relating to spare parts is available on request.

RENOLD PM Series - PW Type - Lubrication Information

The correct fill of oil for the unit size and mounting position can be found in either the appropriate catalogue or the Installation and Maintenance Guide. Only good quality oils should be used, such as those listed below, as the use of inferior or unsuitable products may cause rapid wear and possible damage to the gearbox. Some EP additives such as Sulphur can attack Bronze especially at operating temperatures above 80°C and therefore should be avoided.

Oils with three viscosity ranges (Light, medium and heavy) are listed below, the correct choice depends on the application, operating speed, load and temperature. Temperature and speed can often be the main factor as it effects the operating viscosity. If the unit runs below the catalogue rating and operates at a temperature below 60°C then a light grade oil should be used. Operating at catalogue rating with temperatures up to 90°C requires a medium grade oil and higher temperatures and loading require heavy grade oils. When using POA oils this temperature can be increased by about 5°C.

If the unit is operating with gear speeds below 2.5 m/s (500ft/min) then the next higher grade should be used. Using too heavy a grade than required will result in reduced efficiency, too light a grade will result in premature wear, if in doubt ask Renold Gears Technical Department.

Which Oil to Select

There are three main oils Mineral, Synthetic (Polyalphaolefin) and Synthetic (Polyglycol). Mineral oils tend to be cheaper, have a lower life and are less efficient. Synthetic (Polyalphaolefin) can operate over a higher temperature range, are more efficient, give higher ratings and have a longer life and as such are preferred.

The use of Synthetic (Polyglycol) are not recommended without prior discussion with Renold as special paints and seals are required.

If necessary a list of recommended food grade oils is available on request.

If a Sprag Clutch backstop is fitted internally to the gear unit, oils with EP type additives must not be used.

The oils shown below are all suitable for use with Sprag Clutch backstops.

Mineral Oil	Light		Medium		Heavy	
		Temp°C		Temp°C		Temp°C
Mobil DTE	BB	-7 to 90	AA	2 to 90	HH	2 to 90
Castrol Alpha ZN	220	-9 to 120	320	-9 to 120	460	-9 to 120
Shell Vitrea	220	-24 to 120	320	-18 to 120	460	-15 to 120
Esso Teresso	220	-18 to 120	320	-12 to 120	460	-9 to 120
Kluberoil GEM 1	220	-18 to 100	320	0 to 100	460	0 to 100

Synthetic (Polyalphaolefin)	Light		Medium		Heavy	
		Temp°C		Temp°C		Temp°C
Mobil Gear SHC	630	-42 to 160	632	-42 to 160	634	-39 to 160
Castrol Alpha T	220	-36 to 80	320	-33 to 80	460	-33 to 80
Shell Omala RL	220	-40 to 80	320	-40 to 80	460	-40 to 80
Esso Teresso SHP	220	-42 to 150	320	-36 to 150	460	-30 to 150

RENOLD PM Series - PW Type - Oil Capacities

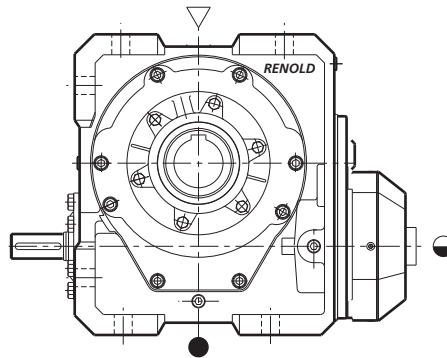

UNDERDRIVEN

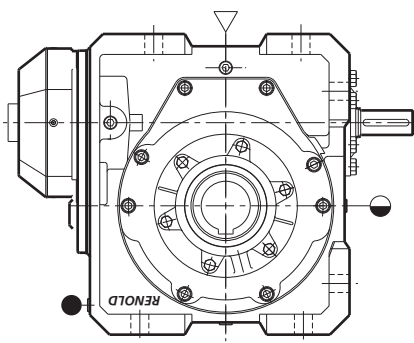

OVERDRIVEN

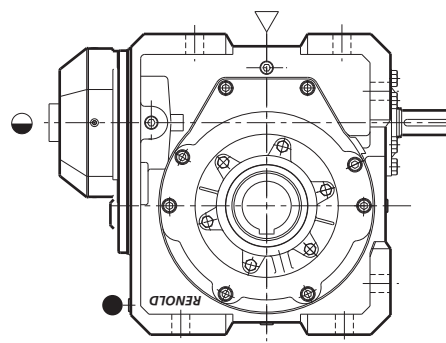

OVERDRIVEN
(SLOW SPEED)

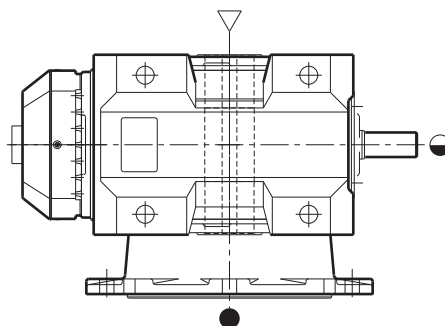

VERTICAL

▽ FILLER/BREATHER PLUG ◐ OIL LEVEL PLUG ● DRAIN PLUG

PM Series PW Single Reduction Oil Quantities (Litres)

UNIT REF	Underdriven	Over driven		Vertical Output -with dry well
		Normal Speed	Slow Speed	
PW35	1.2	2.6	4.0	1.6
PW40	1.8	3.6	7.0	2.9
PW50	3.0	6.6	11.0	5.7
PW60	5.0	10.3	18.0	9.0
PW70	7.7	15.5	27.0	15.0
PW80	9.6	19.0	34.0	18.5

Nominal oil quantity - May vary with ratio

RENOLD PM Series - PW Type - Unit Weights

PM Series PW Single Reduction Weights (kg)

PW35	Foot Mounting			Flange Mounting			Vertical Output (Dry Well)		
	Hollow Shaft	Single Extension	Double Extension	Hollow Shaft	Single Extension	Double Extension	Hollow Shaft	Single Extension	Double Extension
PW35-Red'n gear	54	58	60	59	65	66	61	67	68
PW35 + MD80K	73	77	79	78	84	85	80	86	87
PW35 + MD80G	73	78	79	79	84	86	81	86	88
PW35 + MD90S	76	81	82	82	87	89	84	89	91
PW35 + MD90L	79	83	85	84	90	91	86	92	93
PW35 + MD100L	83	88	89	89	94	96	91	96	98
PW35 + MD100LX	87	92	93	93	98	100	95	100	102
PW35 + MD112M	93	98	99	99	104	106	101	106	108
PW35 + MD132S	109	114	115	115	120	122	117	122	124
PW35 + MD132M	127	131	133	132	138	139	134	140	141

PW40	Foot Mounting			Flange Mounting			Vertical Output (Dry Well)		
	Hollow Shaft	Single Extension	Double Extension	Hollow Shaft	Single Extension	Double Extension	Hollow Shaft	Single Extension	Double Extension
PW40-Red'n gear	77	84	86	88	97	99	89	98	100
PW40 + MD80K	97	104	113	108	117	119	110	119	121
PW40 + MD80G	98	105	114	109	118	120	110	119	121
PW40 + MD90S	101	108	117	112	121	123	113	122	124
PW40 + MD90L	103	110	120	114	123	125	116	125	127
PW40 + MD100L	108	115	124	119	128	130	120	129	132
PW40 + MD100LX	112	119	128	123	132	134	124	133	135
PW40 + MD112M	118	125	134	129	138	140	130	139	141
PW40 + MD132S	134	141	150	145	154	156	146	155	157
PW40 + MD132M	151	158	168	162	171	173	164	173	175

PW50	Foot Mounting			Flange Mounting			Vertical Output (Dry Well)		
	Hollow Shaft	Single Extension	Double Extension	Hollow Shaft	Single Extension	Double Extension	Hollow Shaft	Single Extension	Double Extension
PW50-Red'n gear	112	124	128	126	140	144	128	142	146
PW50 + MD90S	141	153	157	155	169	173	157	171	175
PW50 + MD90L	144	156	159	157	172	175	159	173	177
PW50 + MD100L	149	160	164	162	176	180	164	178	182
PW50 + MD100LX	152	164	168	166	180	184	168	182	186
PW50 + MD112M	158	170	174	172	186	190	174	188	192
PW50 + MD132S	174	186	190	188	202	206	190	204	208
PW50 + MD132M	192	204	207	206	220	223	207	221	225
PW50 + MD160M	249	261	264	262	276	280	264	278	282
PW50 + MD160L	269	281	284	282	296	300	284	298	302

RENOLD PM Series - PW Type - Unit Weights

PM Series PW Single Reduction Weights (kg)

PW60	Foot Mounting			Flange Mounting			Vertical Output (Dry Well)		
	Hollow Shaft	Single Extension	Double Extension	Hollow Shaft	Single Extension	Double Extension	Hollow Shaft	Single Extension	Double Extension
PW60-Red'n gear	174	195	200	191	215	220	194	219	224
PW60 + MD100L	211	232	237	228	252	257	232	256	261
PW60 + MD100LX	215	236	241	232	256	261	235	260	265
PW60 + MD112M	221	242	247	238	262	267	241	266	271
PW60 + MD132S	237	258	263	254	278	283	257	282	287
PW60 + MD132M	255	276	280	271	296	301	275	299	304
PW60 + MD160M	311	332	337	328	352	357	332	356	361
PW60 + MD160L	331	352	357	348	372	377	352	376	381
PW60 + MD180M	365	386	391	382	406	411	386	410	415
PW60 + MD180L	379	400	405	396	420	425	400	424	429

PW70	Foot Mounting			Flange Mounting			Vertical Output (Dry Well)		
	Hollow Shaft	Single Extension	Double Extension	Hollow Shaft	Single Extension	Double Extension	Hollow Shaft	Single Extension	Double Extension
PW70-Red'n gear	248	278	285	274	309	317	280	315	322
PW70 + MD132S	317	347	355	343	378	386	349	384	391
PW70 + MD132M	335	364	372	361	396	403	366	401	409
PW70 + MD160M	396	426	434	422	457	465	428	463	470
PW70 + MD160L	416	446	454	442	477	485	448	483	490
PW70 + MD180M	450	480	488	476	511	519	482	517	524
PW70 + MD180L	464	494	502	490	525	533	496	531	538
PW70 + MD200L	512	542	550	538	573	581	544	579	587
PW70 + MD225S	575	605	612	601	636	643	606	641	649
PW70 + MD225M	610	640	647	636	671	678	641	676	684

PW80	Foot Mounting			Flange Mounting			Vertical Output (Dry Well)		
	Hollow Shaft	Single Extension	Double Extension	Hollow Shaft	Single Extension	Double Extension	Hollow Shaft	Single Extension	Double Extension
PW80-Red'n gear	295	327	337	326	362	372	331	368	378
PW80 + MD132S	367	399	408	397	434	443	403	440	449
PW80 + MD132M	384	416	426	415	451	461	420	457	467
PW80 + MD160M	446	478	487	476	513	523	482	519	528
PW80 + MD160L	466	498	507	496	533	543	502	539	548
PW80 + MD180M	500	532	541	530	567	577	536	573	582
PW80 + MD180L	514	546	555	544	581	591	550	587	596
PW80 + MD200L	562	594	604	592	629	639	598	635	644
PW80 + MD225S	626	658	667	656	693	703	662	699	708
PW80 + MD225M	661	693	702	691	728	738	697	734	743

Notes

Notes

Notes

Terms and Conditions

- In the interests of safety, customers are reminded that when purchasing any technical product for use at work (or otherwise), any additional or up-to-date information and guidance, which it has not been possible to include in the publication, should be obtained by you from your local sales office in relation to the suitability and the safe and proper use of the product. All relevant information and guidance must be passed on by you to the person engaged in, or likely to be affected by or responsible for the use of the product
- The performance levels and tolerances of our product stated in this catalogue (including without limitation, serviceability, wearlife, resistance to fatigue, corrosion protection) have been verified in a programme of testing and quality control in accordance with Renold, independent and/or international standard recommendations. No representations or warranties are given that our product shall meet the stated performance levels or tolerances for any given application outside the performance levels and tolerances for the product's own specific application and environment.

- Whilst all reasonable care in compiling the information contained in this catalogue is taken, no responsibility is accepted for errors.
- All information contained in this catalogue is subject to change without notice.
- The illustrations used in this catalogue represent the type of product described but the goods supplied may vary in some detail from those illustrated.
- The right is reserved to make modifications to the product to meet manufacturing conditions and/or developments (for example in design or materials).
- Product can be supplied by Renold companies or representatives around the world on the standard terms and conditions of sale of the company or representative from which the product is purchased.
- Copyright Renold Power Transmission Limited 2001. All rights reserved.

Nothing contained in this publication shall constitute a part of any contract, express or implied.

RENOLD

A global power transmission group serving global markets through an international network.

For your local Renold sales and service location visit www.renold.com

Superior Technology. Global Expertise.

www.renold.com

gears.sales@renold.com



REN54/CATPMPW/12.15/E
A Business of Renold Power Transmission Ltd.

RENOLD
Superior Gear Technology