

Disc brakes

Technical data and dimensions

Caliper 2SA

Fail safe braking
Braking by spring application
Electromagnetic release
Manual lining wear compensation
Opening proving switch
Air gap switch

Operating conditions:

- Ambient temperature: -10°C to +60°C
- Relative humidity ≤ 70%
- Dust in atmosphere ≥ 65µ
- Other conditions, consult us.

Use:

The brake should be applied only in case of emergency stop, overspeed or shutdown of electric mains.

Options:

- Detection of full lining wear
- Load regulated lowering

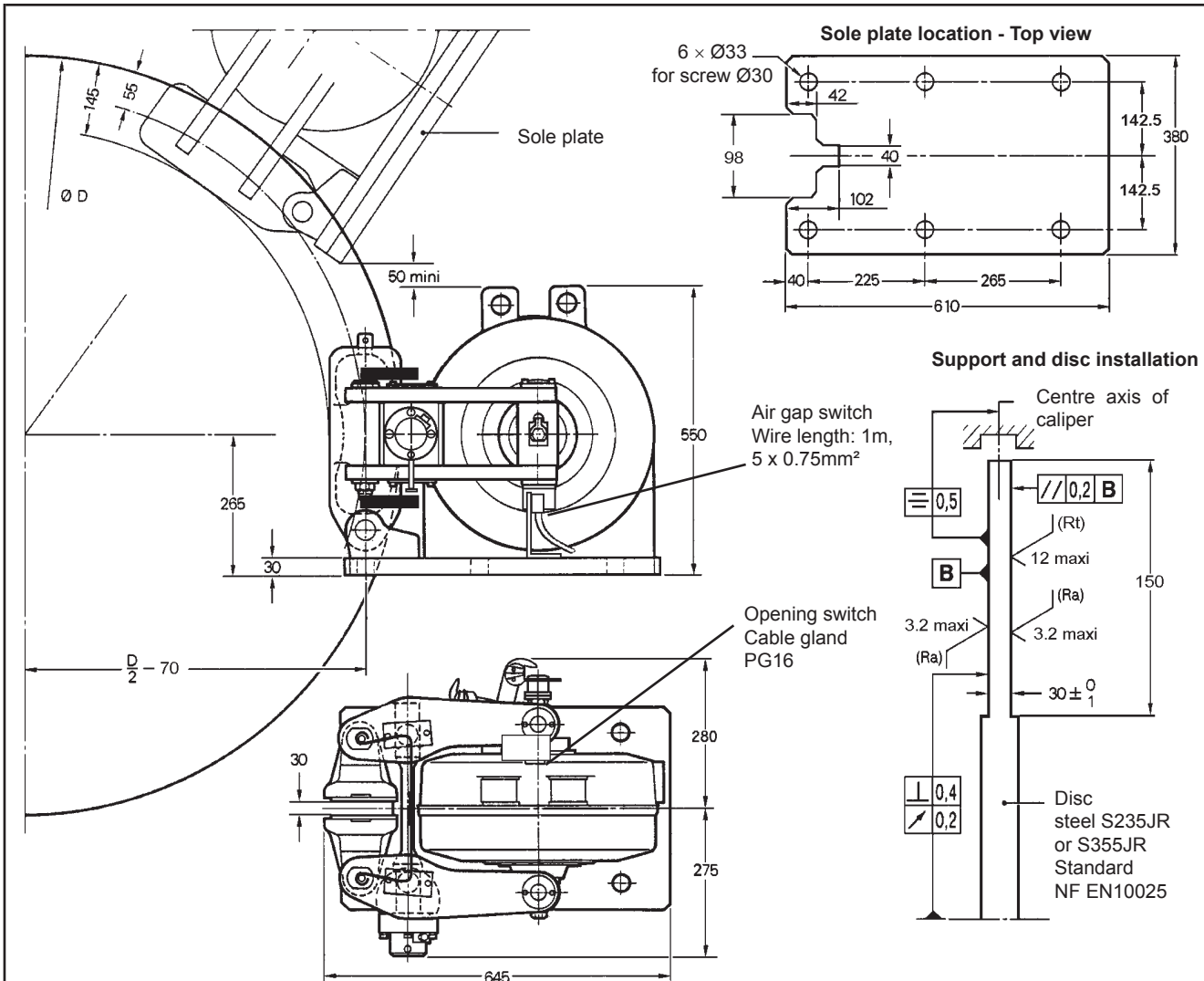

Weight : 400kg

Torque and force values are subject to a variation of ±10%

Response time at nominal torque $\Delta t \leq 0.2$ sec

Designation	Caliper	2SA	
	Lining *	US2-1	US2-5
Braking force BF for 1mm of air gap disc/lining	Static N	90 000	84 600
	Dynamic N	100 000	94 000
Linear speed of the disc	m/s	≤ 10	≤ 10
Dynamic braking torque BT (N.m) for 1 caliper and disc ØD (mm)	N.m	BT = BF(D/2000 - 0,055)	

• Opening proving switch:

250VAC maxi., 5A maxi., with interrupting capacity : 50VA maxi
220VDC maxi., 5A maxi., with interrupting capacity : 50W maxi
Compatible with PLC (Programmable Logic Controllers).
An opening switch used with other equipment than PLC must not be reused with a PLC.

• Air gap switch:

240V, 3A AC
250V, 0.27A DC

- * **US2-1:** disc temperature during one braking ≤ 150°C
US2-5: disc temperature during one braking ≤ 350°C

Due to continuous development and improvement, all dimensions and characteristics are subject to change without notice.

Electrical power unit
Drawings

Leaflet No. T04800-01
No. G06400-01

Installation and maintenance
Spare parts

Leaflet No. M08341-01
No. S09340-01

05/04/12

T03781-01-C